

# SF SUNTOUR

## SF11-XCT-V3-P-26"-80

Date	2010.8.27	Version	1
Amended			

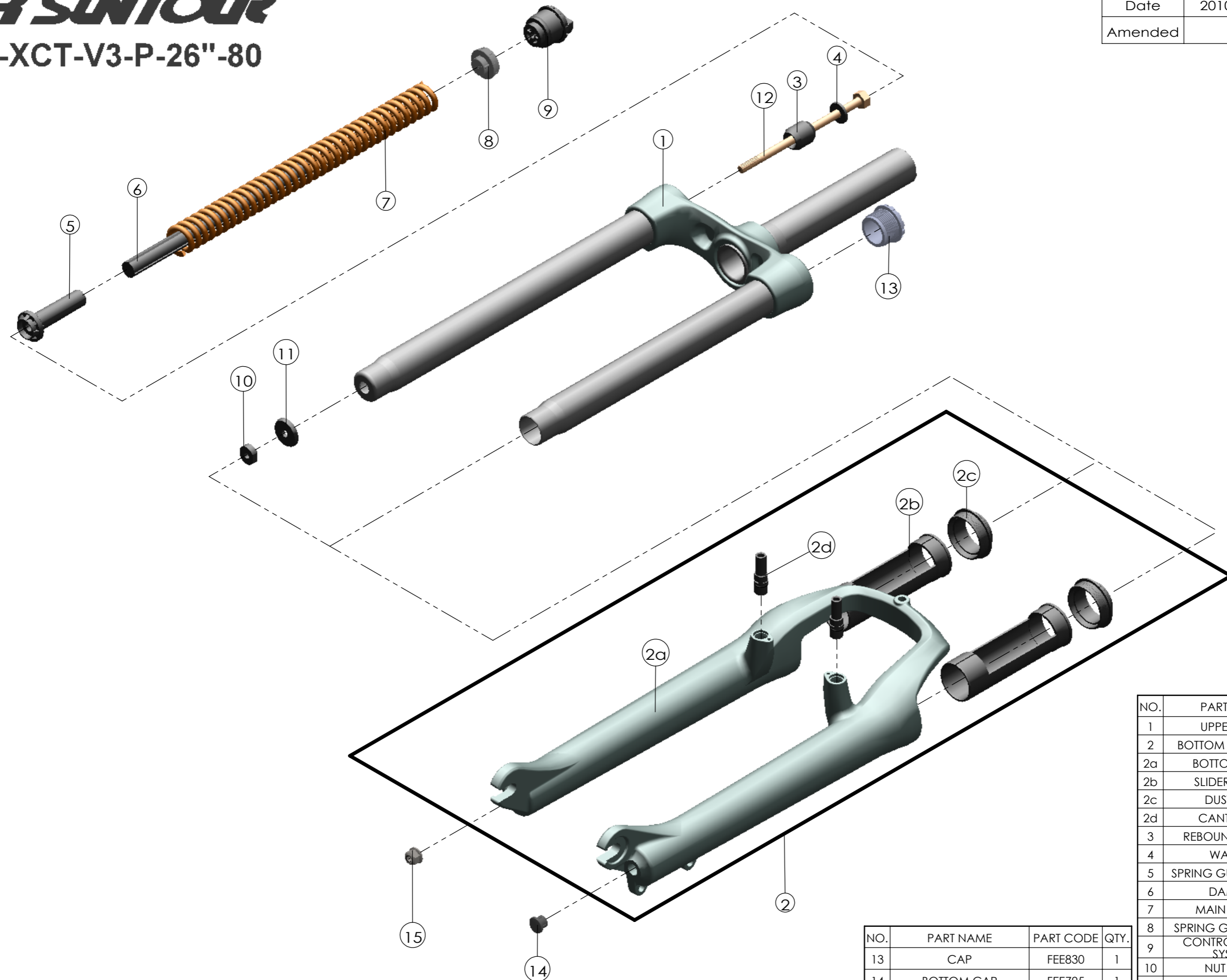

NO.	PART NAME	PART CODE	QTY.
13	CAP	FEE830	1
14	BOTTOM CAP	FEE795	1
15	FIXING NUT	FSN023	1

NO.	PART NAME	PART CODE	QTY.
1	UPPER ASSY	FKE351-11	1
2	BOTTOM CASE ASSY	FKE352	1
2a	BOTTOM CASE	FPB280	1
2b	SLIDER SLEEVE	FEE942	2
2c	DUST SEAL	FAA125-40	2
2d	CANTI BOSS	FSB241-16	2
3	REBOUND RUBBER	FEP086-10	1
4	WASHER	FSW003	1
5	SPRING GUIDE LOWER	FEE502-20	1
6	DAMPER	FEP131-06	1
7	MAIN SPRING	FEP350-30	1
8	SPRING GUIDE UPPER	FEE389-30	1
9	CONTROL ADJUST SYSTEM	FKE008-11	1
10	NUT PLATE	FSN025	1
11	BOTTOM STOPPER	FEE465	1
12	FIXING BOLT	FSB107-10	1