

SUNTOUR

SF22-NVX30-DS-29-63,75,80,100

Date	2022.05.07	Version	1
Amended			

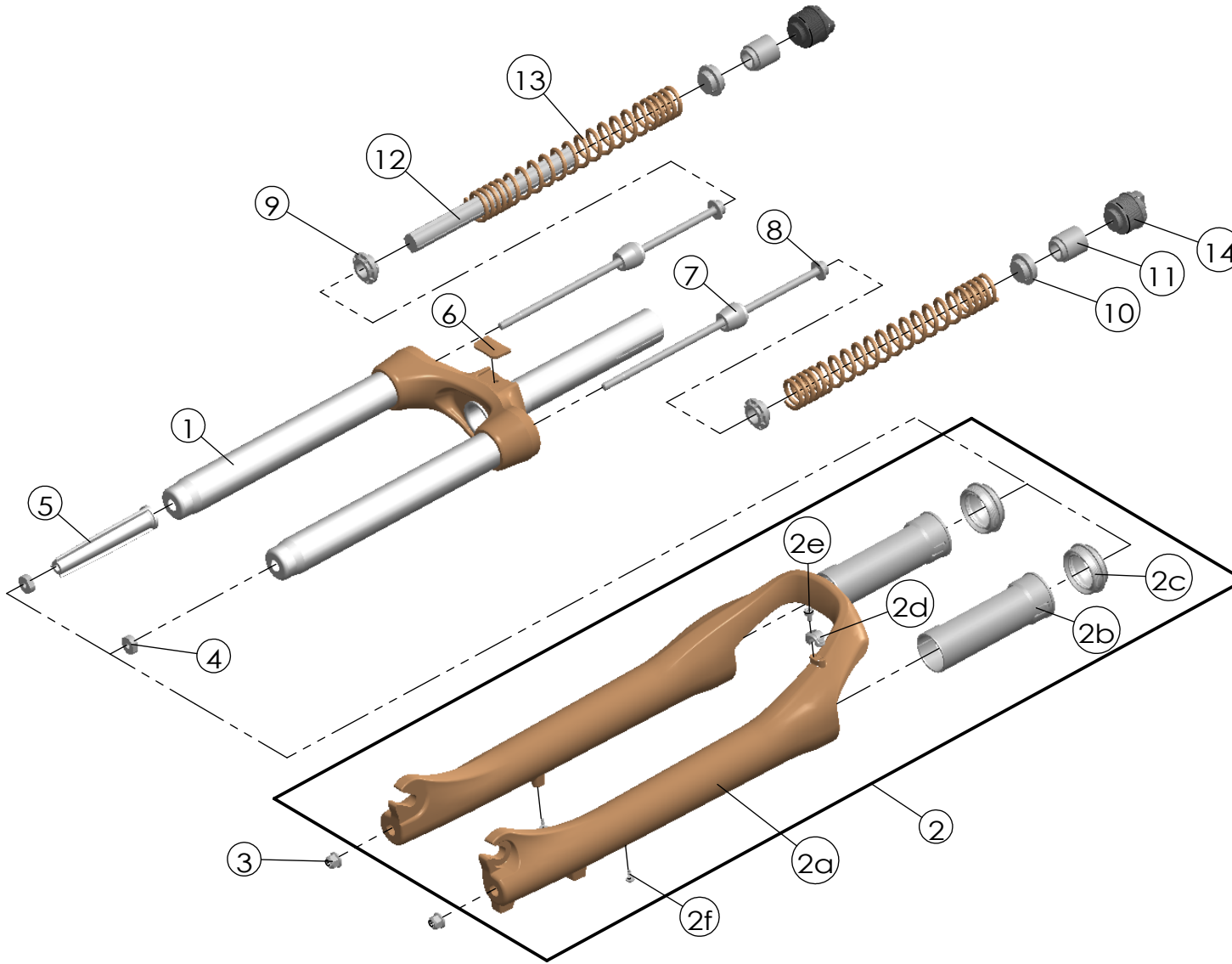

NO.	PART NAME	PART CODE	QTY.			
			63	75	80	100
1	UPPER ASSY	FKZ158-02	1	1	1	-
		FKZ158-03	-	-	-	1
2	BOTTOM CASE ASSY	FKZ160-10	1	1	1	1
2a	BOTTOM CASE	FPB507	1	1	1	1
2b	SLIDER SLEEVE	FEE785	2	2	2	2
2c	DUST SEAL	FAA070-10	2	2	2	2
2d	HOSE GUIDE	FEG166	1	1	1	1
2e	BOLT	FSB153	1	1	1	1
3	FIXING NUT	FSN023	2	2	2	2
4	NUT PLATE	FSN025	2	2	2	2
5	BOTTOM STOPPER	FEG262	1	1	1	-
		FEG262-10	-	-	-	1
6	BRACE COVER	FEG394	1	1	1	1
7	REBOUND RUBBER	FEP086-10	2	2	2	2
8	FIXING BOLT	FSB159-07	2	-	-	-
		FSB159-08	-	2	-	-
		FSB157-05	-	-	2	2
9	SPRING GUIDE LOWER	FEG146-00	2	2	2	2
10	SPRING GUIDE UPPER	FEG434-10	2	2	2	2
11	SPRING GUIDE	FEE992	2	2	2	2
12	DAMPER	FEP320-10	1	-	-	-
		FEP320-20	-	1	1	1
13	MAIN SPRING	FEP729	2	-	-	-
		FEP327-60	-	2	2	-
		FEP319-60	-	-	-	2
14	ADJUSTER ASSY	FKE009-11	2	2	2	2