

SR SUNTOUR

SF22-NVX30-DS-RL-27.5-63,75,80,100

Date	2022.05.07	Version	1
Amended			

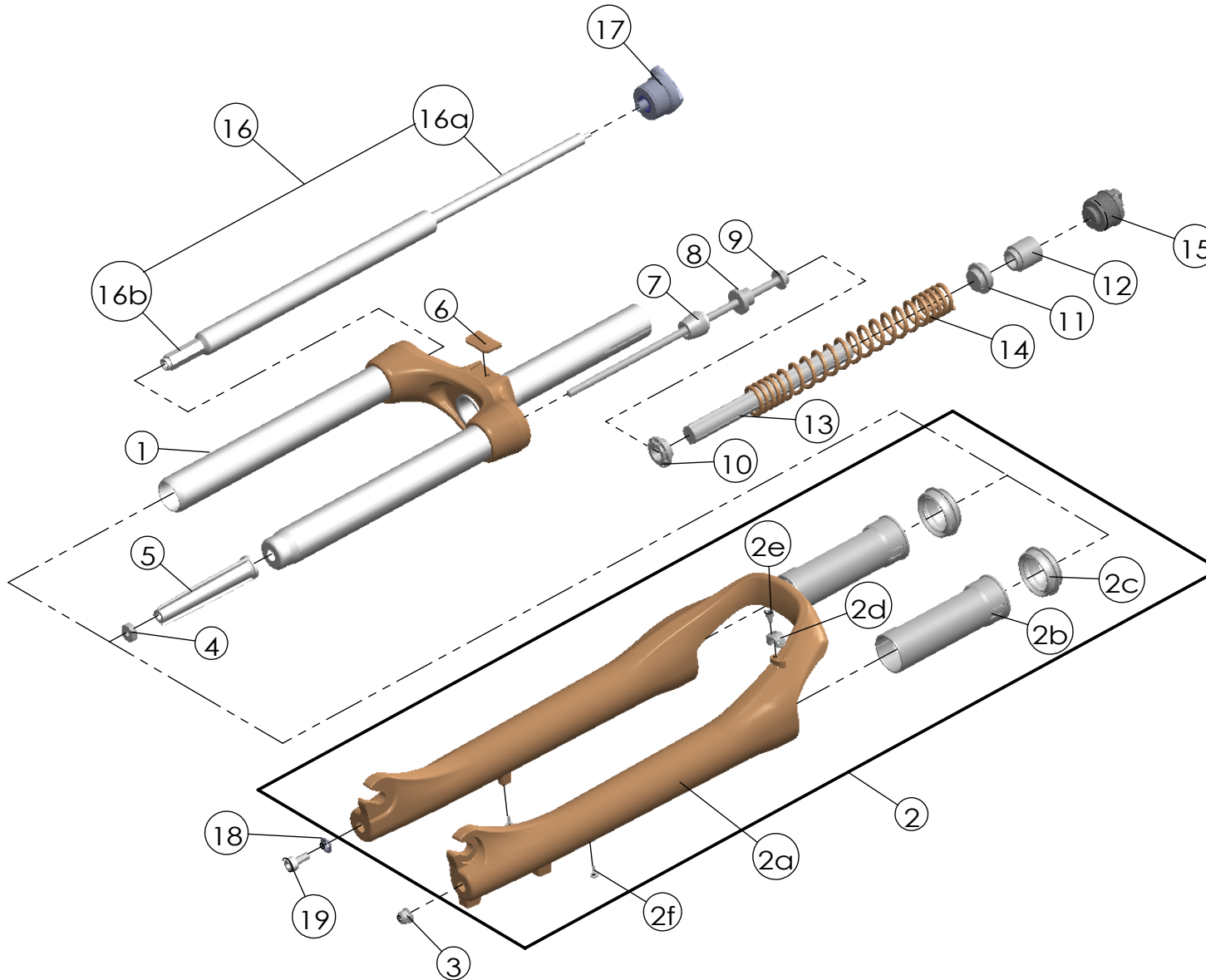

NO.	PART NAME	PART CODE	QTY.			
			63	75	80	100
1	UPPER ASSY	FKE158-04	1	1	-	-
		FKE158-05	-	-	1	-
		FKE158-06	-	-	-	1
2	BOTTOM CASE ASSY	FKE159-10	1	1	1	1
2a	BOTTOM CASE	FPB508	1	1	1	1
2b	SLIDER SLEEVE	FEE785	2	2	2	2
2c	DUST SEAL	FAA070-10	2	2	2	2
2d	HOSE GUIDE	FEG166	1	1	1	1
2e	BOLT	FSB153	1	1	1	1
2f	MOUNT CAP	FAA199	2	2	2	2
3	FIXING NUT	FSN023	1	1	1	1
4	NUT PLATE	FSN025	1	1	1	1
5	BOTTOM STOPPER	FEG262	1	1	-	-
		FEG178	-	-	1	-
		FEG045	-	-	-	1
6	BRACE COVER	FEG394	1	1	1	1
7	REBOUND RUBBER	FEP086-10	1	1	1	1
8	DAMPER SPACE	FEE452	1	-	-	-
9	FIXING BOLT	FSB159-07	-	-	1	1
		FSB159-08	1	1	-	-
10	SPRING GUIDE LOWER	FEG593-10	1	1	-	-
		FEG146-00	-	-	1	1
11	SPRING GUIDE UPPER	FEG592-10	1	1	-	-
		FEG434-10	-	-	1	1
12	SPRING GUIDE	FEE992	-	-	1	1
13	DAMPER	FEP322-20	1	1	-	-
		FEP320-20	-	-	1	1
14	MAIN SPRING	FEP717	1	-	-	-
		FEP863	-	1	-	-
		FEP439	-	-	1	-
		FEP438	-	-	-	1
15	ADJUSTER ASSY	FKE009-11	1	1	1	1
16	DAMPER UNIT	FUN015-09	1	-	-	-
		FUN015-08	-	1	1	1
16a	DAMPER BODY	FUN015-00	1	1	1	1
16b	SUPPORT TUBE	FEE314-15	1	-	-	-
		FEE314-14	-	1	1	1
17	ADJUST SYSTEM	FKE310-10	1	1	1	1
18	WASHER	FSW025	1	1	1	1
19	BOLT	FSB070	1	1	1	1