

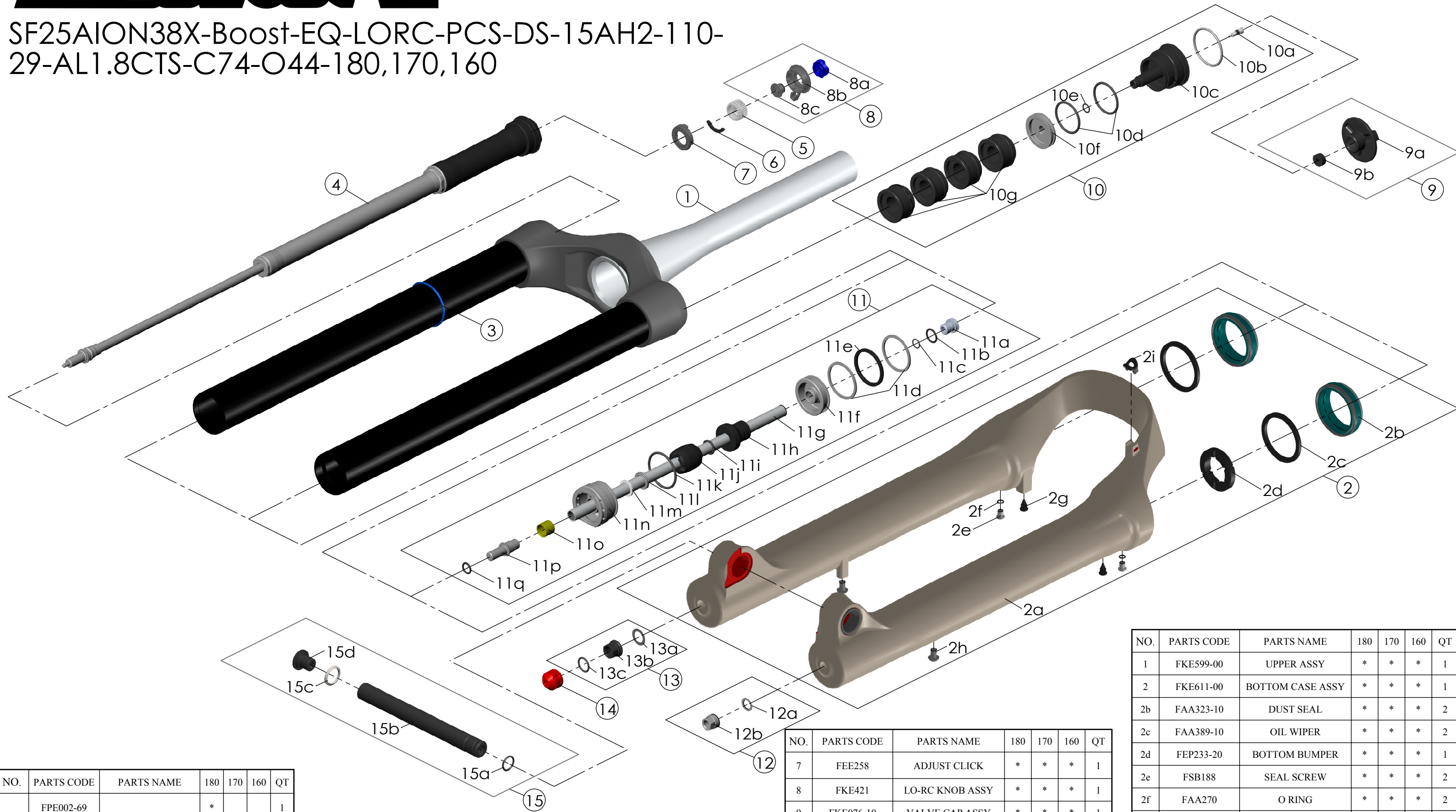

Date	2024.10.09	Version	0
Amended			

SF25AION38X-Boost-EQ-LORC-PCS-DS-15AH2-110-29-AL1.8CTS-C74-O44-180,170,160



NO.	PARTS CODE	PARTS NAME	180	170	160	QT
11g	FPE002-69	SUPPORT TUBE	*			1
	FPE002-68			*		1
	FPE002-67				*	1
12	FKA063-03	FIXING NUT SET	*	*	*	1
13	FKE436-10	FIXING NUT SET	*	*	*	1
14	FEG201	REBOUND KNOB	*	*	*	1
15	FKA117-00	15AH2-110 AXLE SET	*	*	*	1

NO.	PARTS CODE	PARTS NAME	180	170	160	QT
11g	FPE002-69	SUPPORT TUBE	*			1
	FPE002-68			*		1
	FPE002-67				*	1

NO.	PARTS CODE	PARTS NAME	180	170	160	QT
7	FEE258	ADJUST CLICK	*	*	*	1
8	FKE421	LO-RC KNOB ASSY	*	*	*	1
9	FKE076-10	VALVE CAP ASSY	*	*	*	1
10	FKE525-04	VOLUME ADJUSTER ASSY	*			1
				*		1
10g	FEG270-30	VOLUME REDUCER	*			2
				*		3
					*	4

NO.	PARTS CODE	PARTS NAME	180	170	160	QT
1	FKE599-00	UPPER ASSY	*	*	*	1
2	FKE611-00	BOTTOM CASE ASSY	*	*	*	1
2b	FAA323-10	DUST SEAL	*	*	*	2
2c	FAA389-10	OIL WIPER	*	*	*	2
2d	FEP233-20	BOTTOM BUMPER	*	*	*	1
2e	FSB188	SEAL SCREW	*	*	*	2
2f	FAA270	O RING	*	*	*	2
2g	FAA199	MOUNT CAP	*	*	*	2
2h	FSB203	FIXING BOLT	*	*	*	2
2i	FEG034	CABLE CLIP	*	*	*	1
3	FAA397-20	O RING	*	*	*	1
4	FUN131-79	LORC-PCS UNIT	*	*	*	1
5	FEE256-30	ADJUST CORE	*	*	*	1
6	FEE257	CLICK HOLDER	*	*	*	1