

# WORKSHOP MANUAL



HUMAN ELECTRO SYNERGY COMPONENTS



## Contents

User manual for rear wheel motor.....	4
EC Declaration of Conformity.....	21
Installation instructions for ATS crank unit.....	24
Installation instructions for rear wheel motor.....	22
Installation instructions for rear wheel motor display.....	26
Installation instructions for the controller.....	27
Cable harness for rear wheel motor.....	28
Spare parts for rear wheel motor.....	29
Battery charger instruction manual.....	31
Frequently asked questions.....	32



E-Bike components

User manual

Rear wheel motor

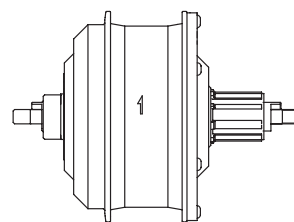

Contents	
Safety information.....	3
Riding the E-Bike.....	5
Product features and specifications.....	6
Display / lighting.....	7
Battery.....	8
Battery charger.....	8
Charging the battery.....	9
Battery charging indicator.....	9
Charging alternatives.....	10
Battery faults.....	10
Battery state of health (SOH).....	10
Inserting the battery.....	11
Removing the battery.....	11
Switching the bike ON/OFF.....	12
Base screen display.....	13
1. Current speed.....	13
2. Display for changing assist mode.....	13
3. Assist level indicator.....	13
4. Battery state of charge (SOC).....	14
5. Range.....	14
6. Changing trip information.....	15
7. Changing background lighting.....	15
Headlight and taillight.....	16
Charging support function.....	16
Overheating warning.....	16
Error codes.....	17
EC Declaration of Conformity.....	18

## Safety information

### WARNING

There is an increased risk of injury – even fatal – if you do not follow instructions.

#### Managing the battery

- ▶ Use only batteries and chargers from SR Suntour with your bike. Use of other battery packs can cause injury and involve a risk of fire. If you use other battery packs, SR Suntour will assume no liability or warranties.
- ▶ Do not throw the battery pack into a fire.
- ▶ The battery must not be exposed to direct sunlight, or charged or stored in the vicinity of high temperatures.
- ▶ Do not use the battery for any other purpose.
- ▶ Avoid contact with metal objects (paper clips, coins, keys, nails, screws, or other small metal objects, as this may cause a short-circuit. Shorts caused in this way will invalidate any warranty claims.
- ▶ Do not open the battery pack. This could cause a short circuit. Opening of the battery package will invalidate any warranty claims.
- ▶ Do not connect, or disconnect the battery pack / charger with wet hands.
- ▶ Keep the battery / charger out of reach of children/animals.

### WARNING

There is a risk of serious injury – even fatal – if you do not follow instructions.

#### How safe riding is ensured

- ▶ While riding, do not focus your attention too much on the screen, as this can lead to accidents.
- ▶ Ensure that the wheels are securely attached to the bike before you begin your trip. If the wheels are not securely attached, the bike may fall over, causing severe damage.
- ▶ When riding a power-assisted bike, be sure that you are completely familiar with the starting characteristics of the bike before riding on multilane roads and footpaths. If the bike suddenly switches on, accidents can happen.
- ▶ If applicable, check that the bike lights are working before you ride at night.

#### How safe riding is ensured

- ▶ Remove the battery pack from the eBike before you start working on it (e.g., assembly work, maintenance, working on the chain, etc.), before transporting it by car or plane, or before storing it. There is a risk of injury in case of accidental activation of the eBike system.
- ▶ Be sure to remove the battery before you perform wiring or installation work on the bike. Otherwise there is a danger of electric shock.
- ▶ When you install this product, be sure to follow the instructions given in the user manual. We also recommend that you use only genuine SR SUNTOUR parts. If nuts and bolts are left loose or the product is damaged, the bike may fall over suddenly and cause serious injury.
- ▶ After you have carefully read the user manual, store it in a safe place for later reference.
- ▶ Ensure that unused connections are provided with caps.
- ▶ Contact a retailer for installation and adjustment of the product.
- ▶ To allow riding in wet weather, the product is designed to be completely waterproof. Nevertheless, do not expose the product intentionally to water.
- ▶ Do not expose the bike to high-pressure cleaning. If water should penetrate into one of the components, operating problems or rust may result.

## Managing the battery

- ▶ Do not subject the battery or the charger to physical shocks, e.g., by dropping. Rinse in the event of accidental contact with water. If fluid gets in your eyes, seek medical advice. Fluid that leaks from the battery pack may cause skin irritation or burns.
- ▶ If you detect a strange odour or smoke, pull the plug.
- ▶ Ensure that the power plug is fully inserted into the wall outlet.
- ▶ Pull on the plug instead of the cable to unplug the power cord from a wall outlet.
- ▶ Do not place anything on the cable. Do not lay anything on the cable.
- ▶ Do not bend the cable. The cable must not be rolled up while charging.
- ▶ It is dangerous to use a single outlet for multiple devices.
- ▶ If the cable or plug is damaged, replace the parts with new ones. Contact your authorized dealer.
- ▶ Always keep your charging set away from flammable gases when charging.
- ▶ The charger can be hot. Do not wrap the charger.
- ▶ The charger can be hot. Do not place the charger on floor coverings such as carpets, tatamis, etc.
- ▶ The charger can be hot. Avoid long skin contact with the charger.
- ▶ Do not immerse the battery or the charger. Do not use in rain.
- ▶ Do not charge the battery for more than 24 hours continuously.
- ▶ If the battery is not fully charged after six hours, disconnect it immediately from the output to stop the charging process and contact your place of purchase. This can lead to overheating, bursting, or ignition of the battery.

## WARNING

There is a danger of personal injury or property damage

### How safe riding is ensured

Follow the instructions in the user manual of the bike to ensure a safe ride.

## Managing the battery

- ▶ The battery comes with a 40% charge. Discharge and charge the battery fully twice to reach an optimum range.
- ▶ Charge the battery before riding.
- ▶ The charger can be used with an input voltage in the range of 100V to 240VAC.
- ▶ After charging pull the cable from the battery and from the wall outlet.
- ▶ Keep the power plug clean and dust free. The charger should be cleaned regularly.
- ▶ Do not rotate the pedals while the battery is being charged and is on the battery holder.
- ▶ Provide ventilation/venting while the battery is charging in enclosed spaces.
- ▶ During storage keep the battery at a charge level of at least 40%.
- ▶ Charge the battery at room temperature between 5°C and 35°C (41°F and 95°F).

## Safe use of the product

- ▶ Examine the battery charger regularly for damage, especially the cable, plug and housing. If the battery charger is damaged, it must only be used after it has been repaired.
- ▶ This product must not be used by persons (including children) with reduced physical, sensory or mental capabilities, or who lack experience and knowledge, unless they are supervised by a person responsible for their safety, or instructed in the use of the product.
- ▶ Do not let children play near the product.

# Riding the E-Bike

**1**

Fit the battery and push the battery ON/OFF button

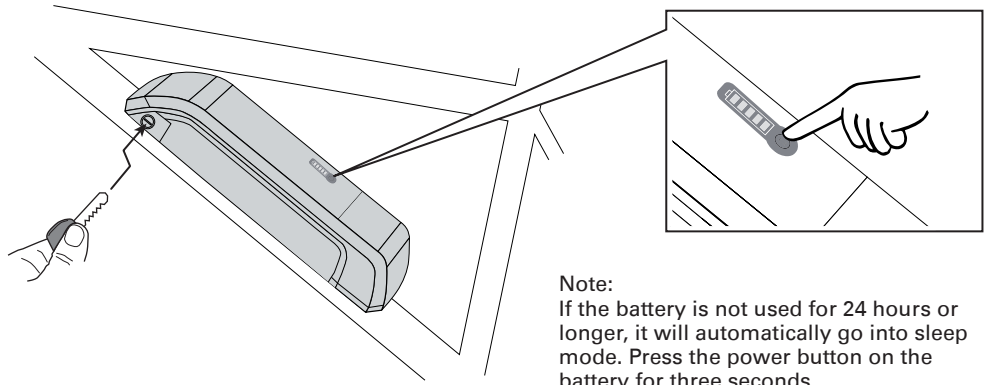

**Note:**  
If the battery is not used for 24 hours or longer, it will automatically go into sleep mode. Press the power button on the battery for three seconds.

**2**

Switch on the bike

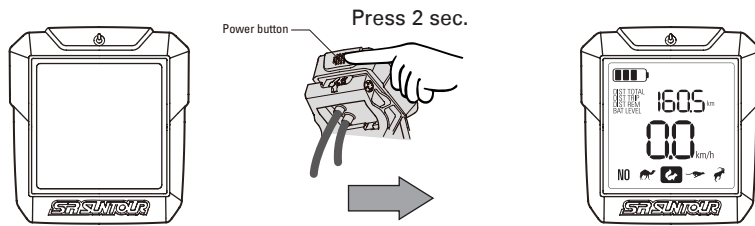

**3**

Select mode

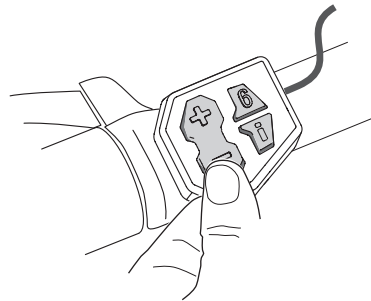

**4**

Start riding

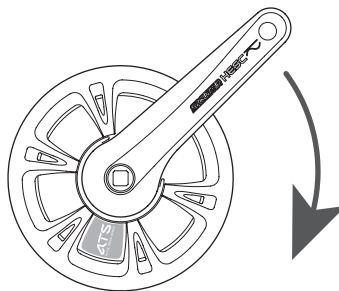



## Product characteristics

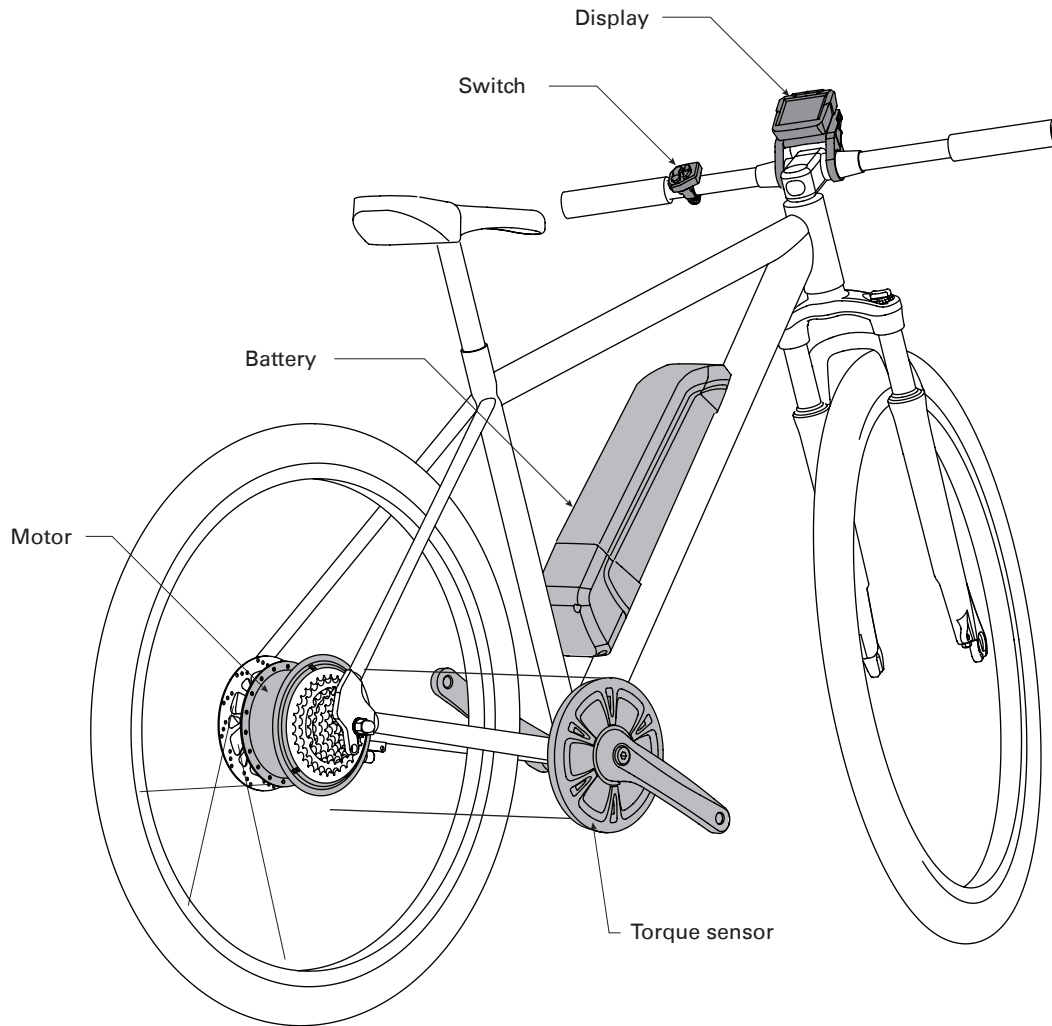

## Product specifications

<b>Operating temperature range during discharge</b>	-20°C to 60°C
<b>Operating temperature range during charge</b>	0°C to 45°C
<b>Storage temperature (battery)</b>	-20°C to 45°C
<b>Humidity (storage)</b>	up to 80%
<b>Charging voltage</b>	100V to 240VAC
<b>Charging time</b>	approx. 6 hours
<b>Battery type</b>	Lithium ion battery
<b>Capacity</b>	417Wh
<b>Nominal voltage</b>	36VDC
<b>Motor type</b>	Rear-wheel drive
<b>Motor type</b>	Brushless DC Motor
<b>Nominal motor power</b>	250W
<b>Maximum motor power</b>	400W
<b>Torque</b>	50Nm

**Display**

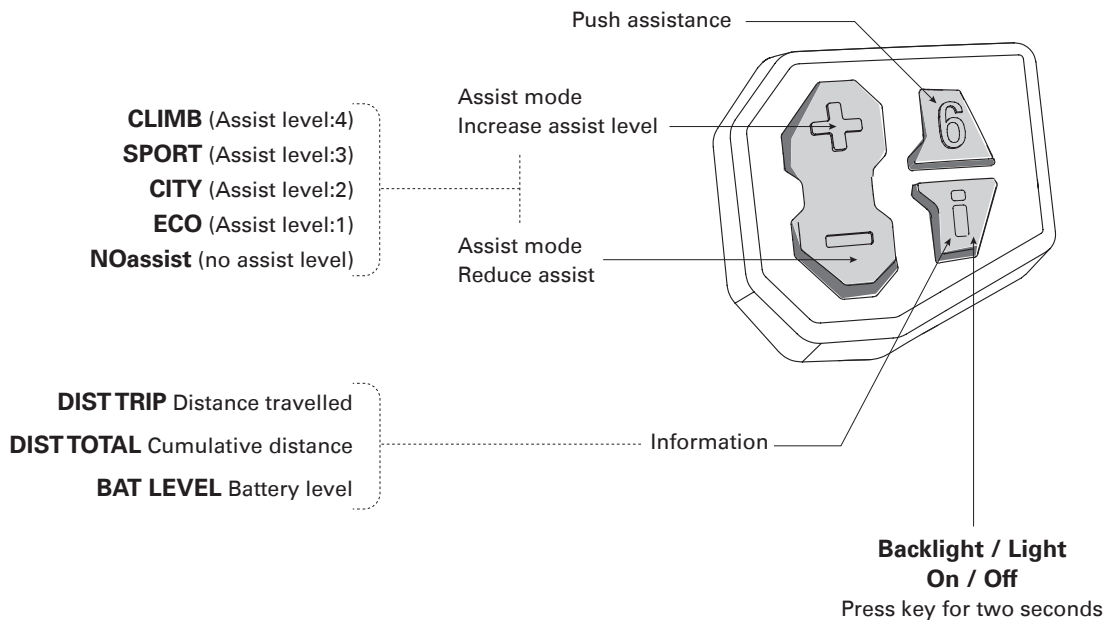
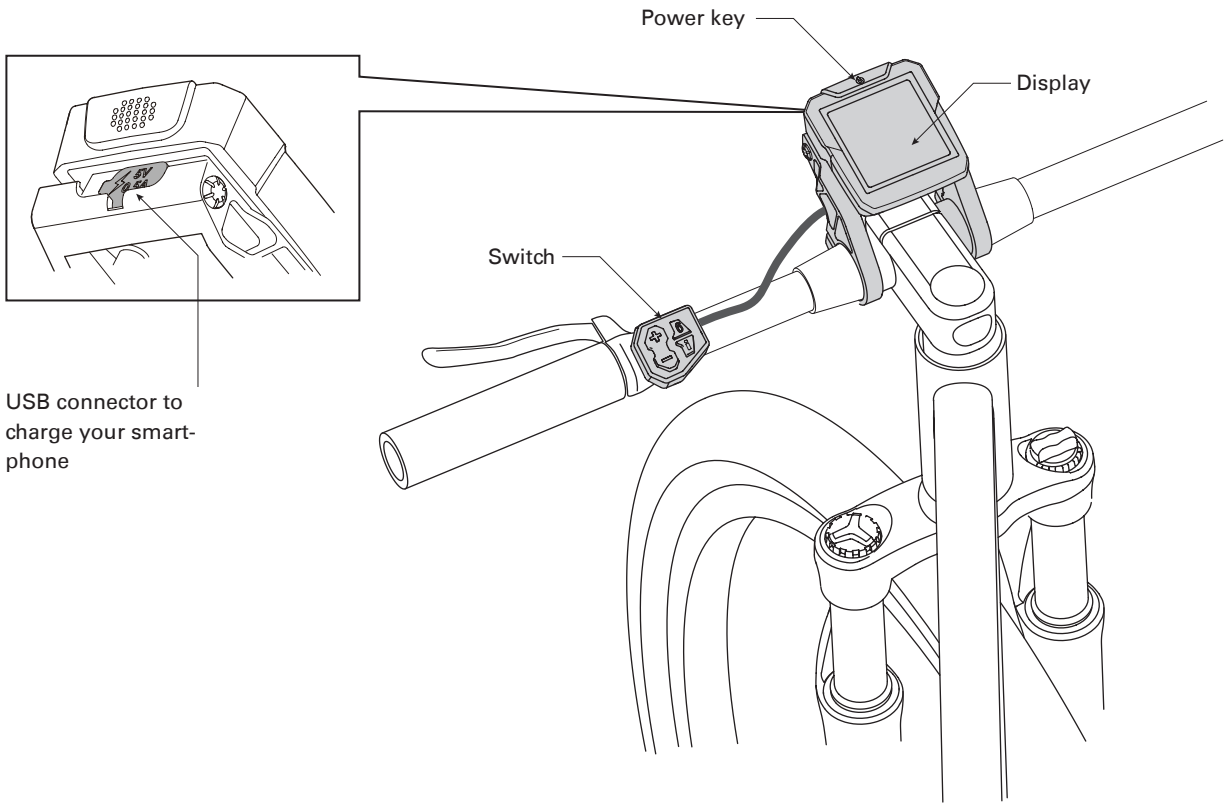

## Battery

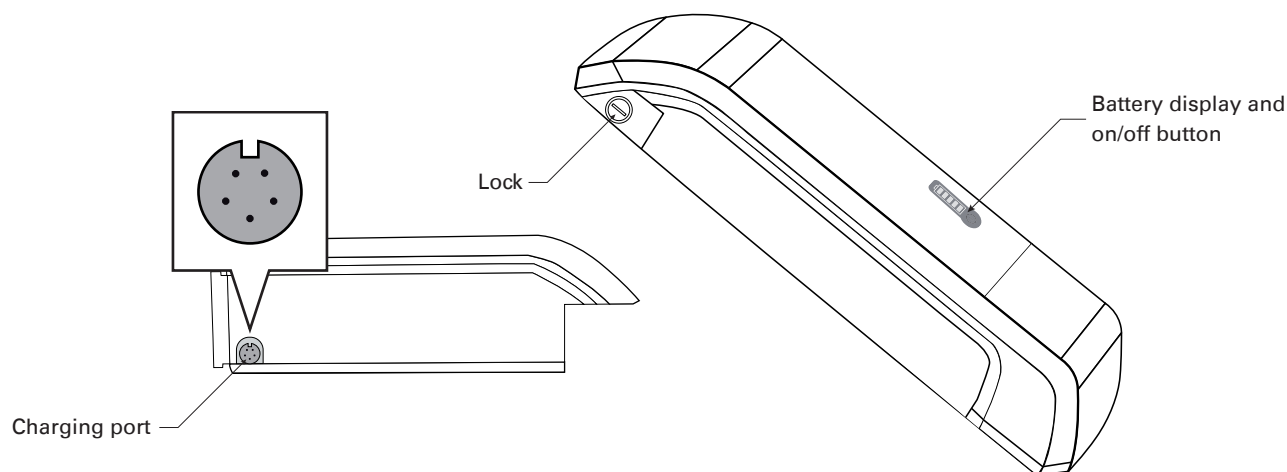

- ▶ If the E-Bike not in use, remove the battery and store it at a temperature between 0°C and 40°C in a dry environment.
- ▶ Do not store the battery with low capacity for a longer period.
- ▶ For storage, the battery should have a capacity of at least 40%.
- ▶ It is recommended to always discharge the battery completely and then fully charge it.

### Retailer note: (only in retailer workbook)

Store the battery separately from the E-Bike. Regularly check the charge status of the battery and maintain at least 40%. Make sure the battery level is at 100% before the first ride. Completely charge and discharge the Battery for the first 5-10 times to reach full capacity. After a complete discharge or charge, we recommend leaving the battery for 1–2 hours before charging or discharging again.

## Battery charger

### ⚠ WARNING

- ▶ Use only batteries and chargers from SR SUNTOUR with your bike. Use of other battery packs can cause injury and involve a risk of fire. If you use other battery packs, we will assume no liability or honour warranties.
- ▶ The battery must not be exposed to direct sunlight, or charged or stored in the vicinity of high temperatures.
- ▶ Avoid contact with metal objects (paper clips, coins, keys, nails, screws, or other small metal objects, as this may cause a short-circuit. Shorts caused in this way will invalidate any warranty claims.
- ▶ Do not open the battery pack. This could cause a short circuit. Opening of the battery package will invalidate any warranty claims.
- ▶ Do not connect, or disconnect the battery pack/charger with wet hands.
- ▶ Keep the battery/charger out of reach of children and animals.

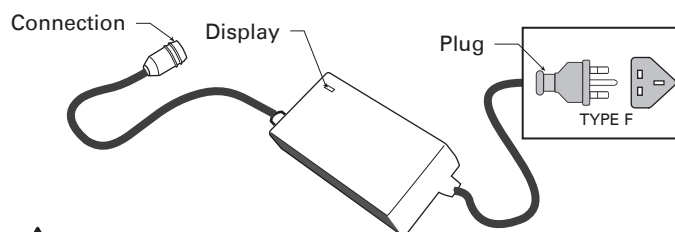

### ⚠ WARNING

- ▶ Do not subject the battery or the charger to physical shocks, e.g., by dropping. Rinse in the event of accidental contact with water. If fluid gets in your eyes, seek medical advice. Fluid that leaks from the battery pack may cause skin irritation or burns.
- ▶ Do not bend the cable. The cable must not be rolled up while charging.
- ▶ The charger can be hot. Do not wrap the charger and place it on floor coverings such as carpets, etc.
- ▶ If the battery is not fully charged after six hours, disconnect it immediately from the output to stop the charging process and contact your place of purchase. This can lead to overheating, bursting, or ignition of the battery.

## Charging the battery

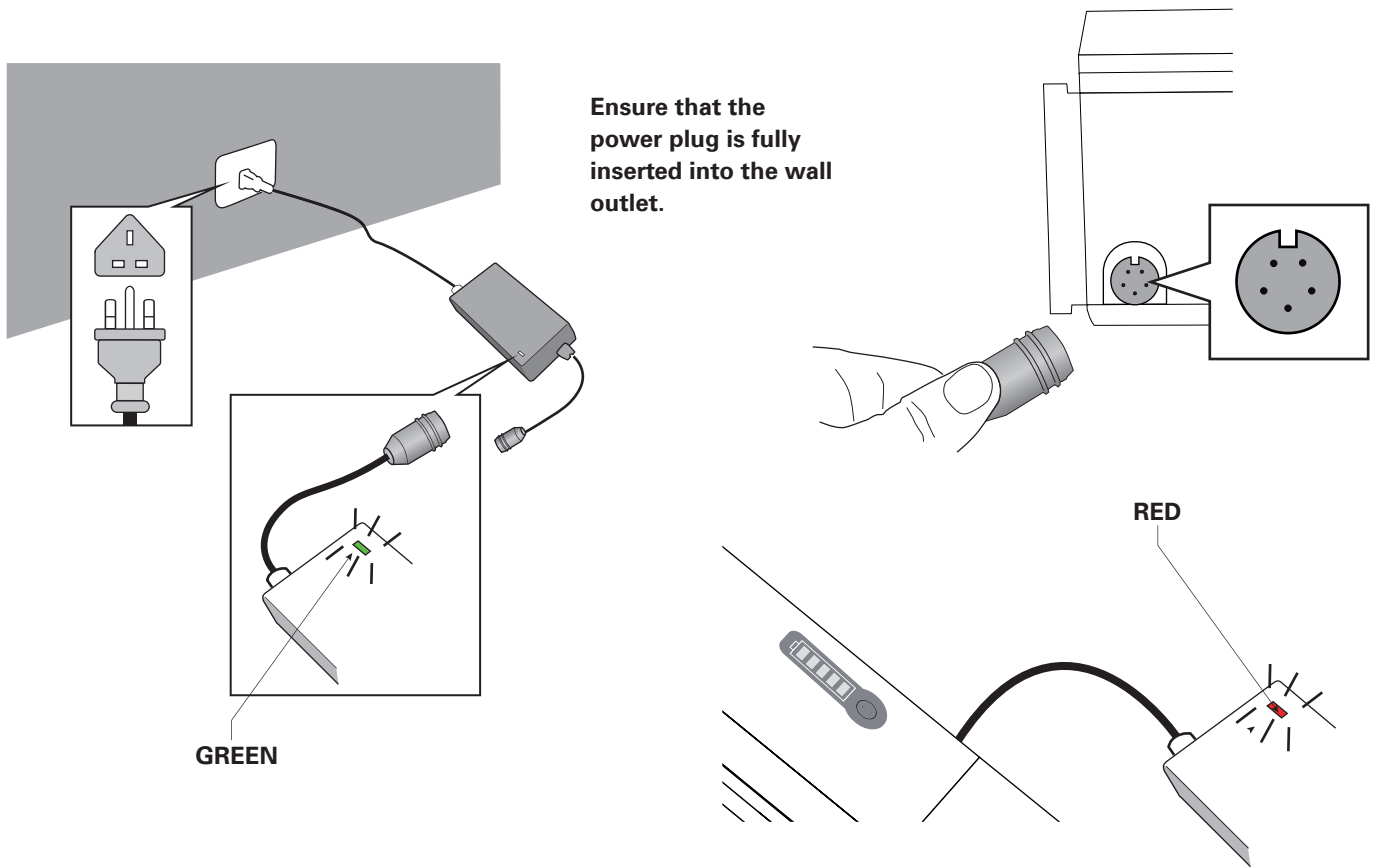

## Battery charging indicator

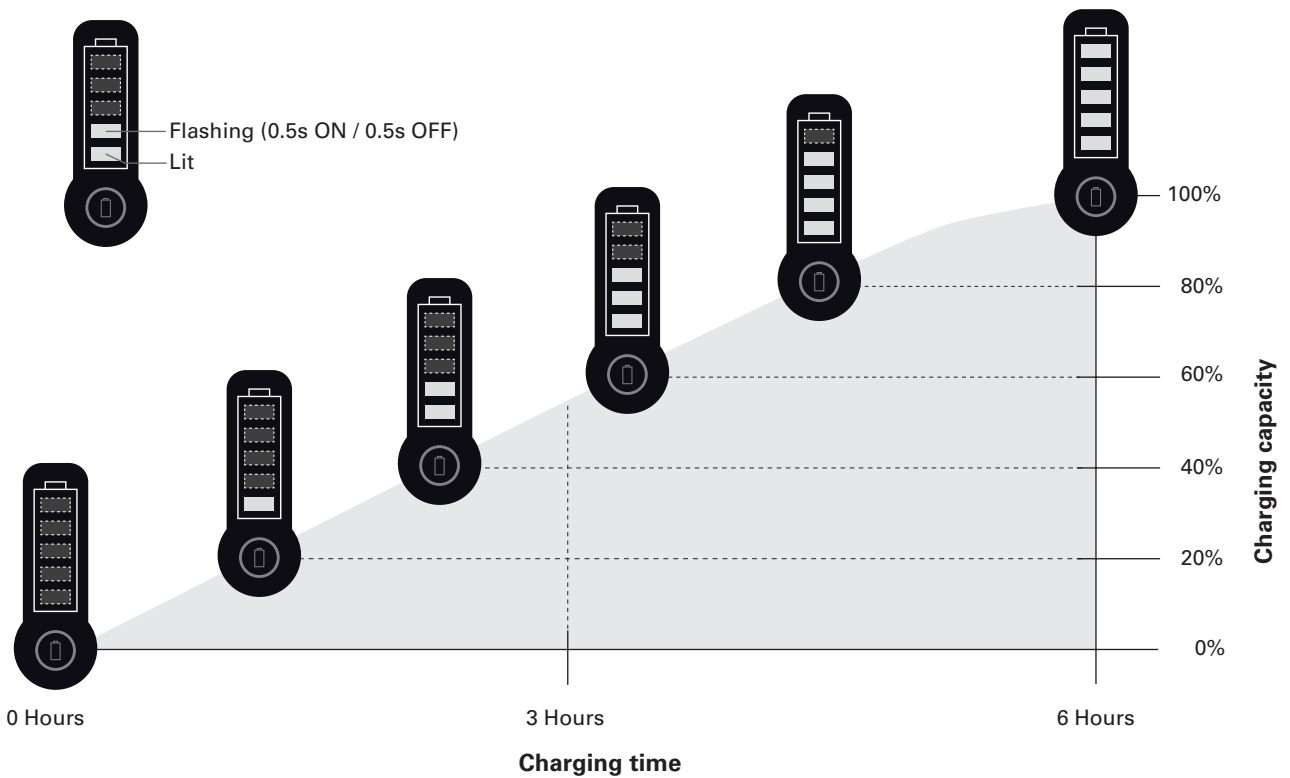



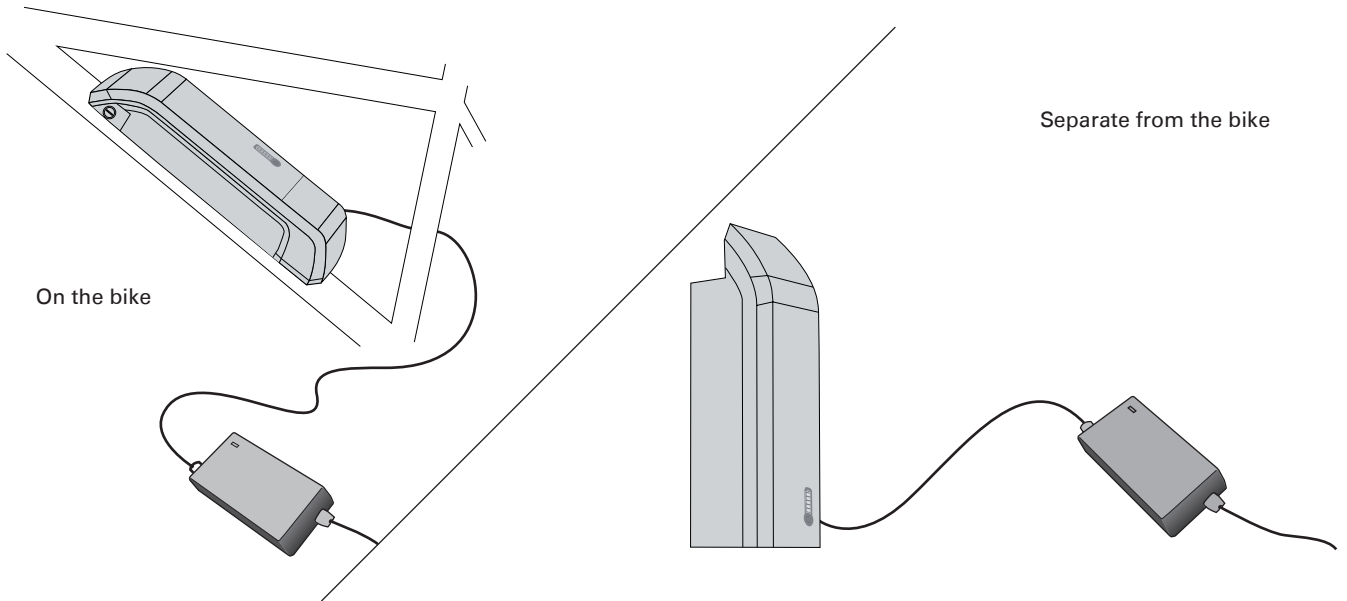

Every three months or after 40 sub-cycles, you should perform a complete discharge and recharge.

## Charging alternatives







## Battery faults

Push the button briefly.

One LED steadily lit the other flashing 0.5s ON / 0.5s OFF				
<b>Fault</b>	Over temperature	Over Voltage of cell	Bad cell	Charge MOSFET defective
<b>Action</b>	Stop using this battery pack	Stop using this battery pack	Stop using this battery pack	Stop using this battery pack

## Battery state of health (SOH)

Press and hold the button for 10 seconds one of the following patterns of the LEDs will be displayed showing the remaining capacity of the battery - Battery State Of Health (SOH).

All LEDs flashing for 10 seconds					
<b>SOH remaining capacity</b>	<60%	60-70%	70-80%	80-90%	>90%
<b>Action</b>	If <2 years old, battery replacement	N/A	N/A	N/A	N/A

## Inserting the battery

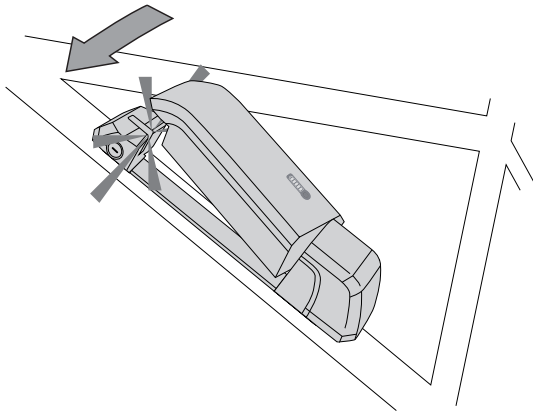

The battery must latch on with an audible click.

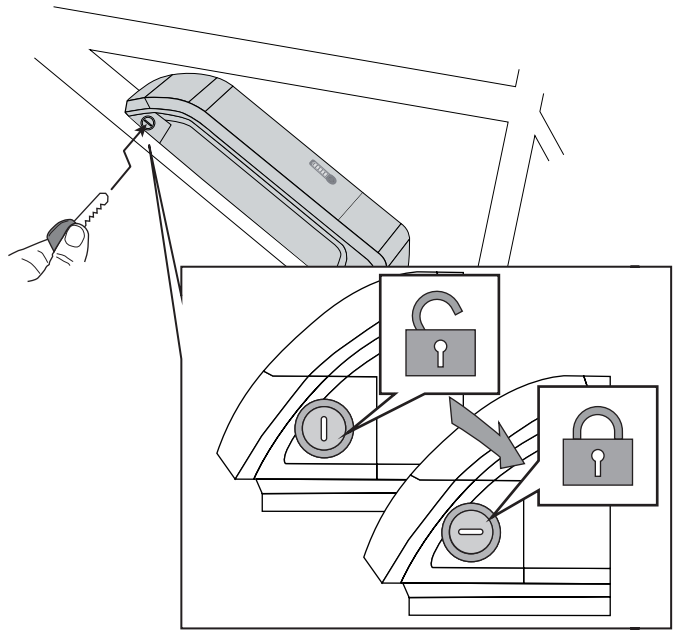

## Removing the battery

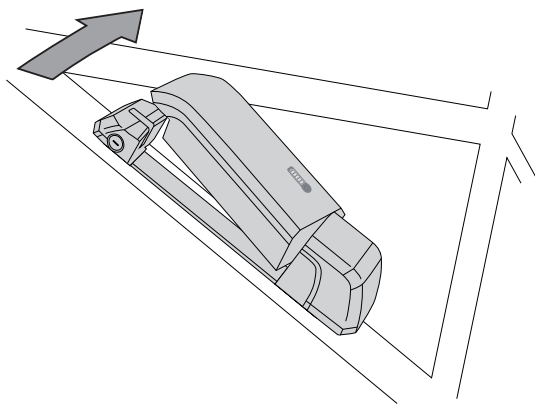
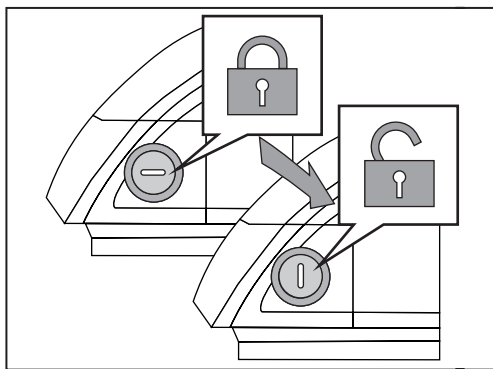
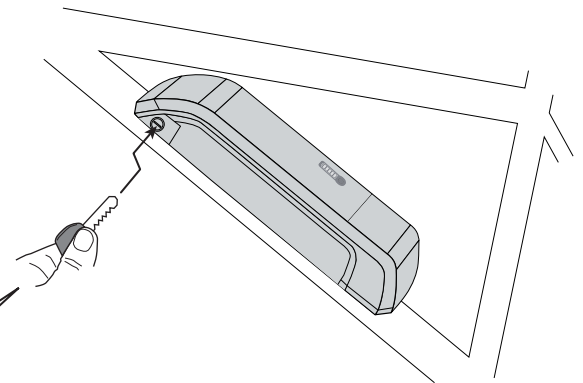
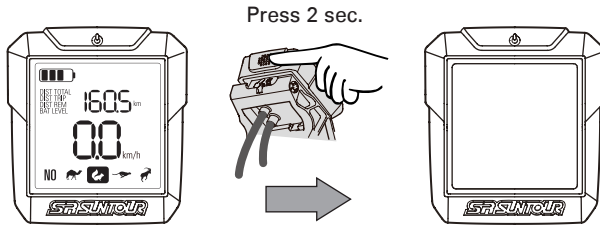

## Switching the bike ON/OFF

### SWITCHING ON

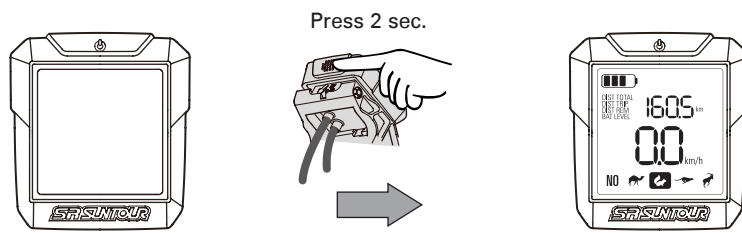

Note:

If the system won't start by pressing the displays switch, press the power button on the battery for three seconds.  
Explanation: If the battery is not used for 24 hours or longer, it will automatically go into sleep mode.

### SWITCHING OFF

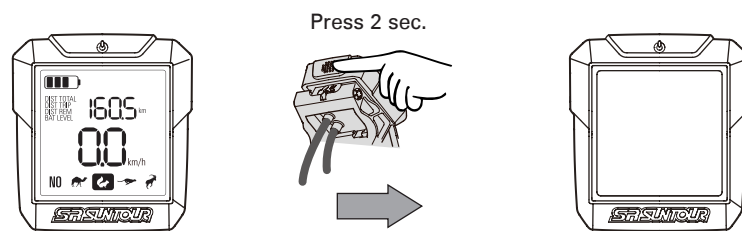

### Automatic SWITCHING OFF



## Base screen display

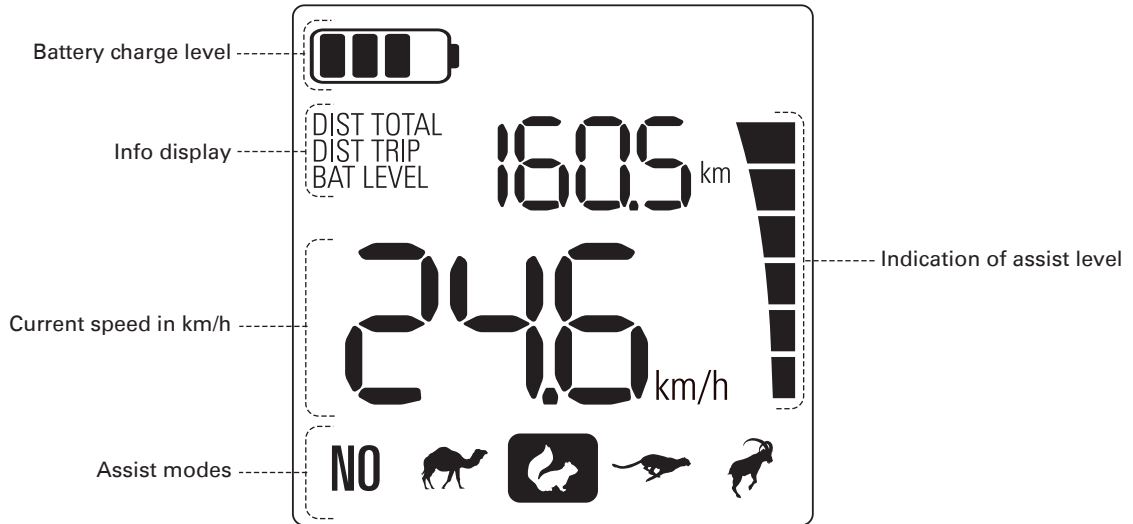

### 1. Current speed

Unit: km/h

Measurement range: 0.0 to 99.9 km/h

### 2. Display for changing assist mode

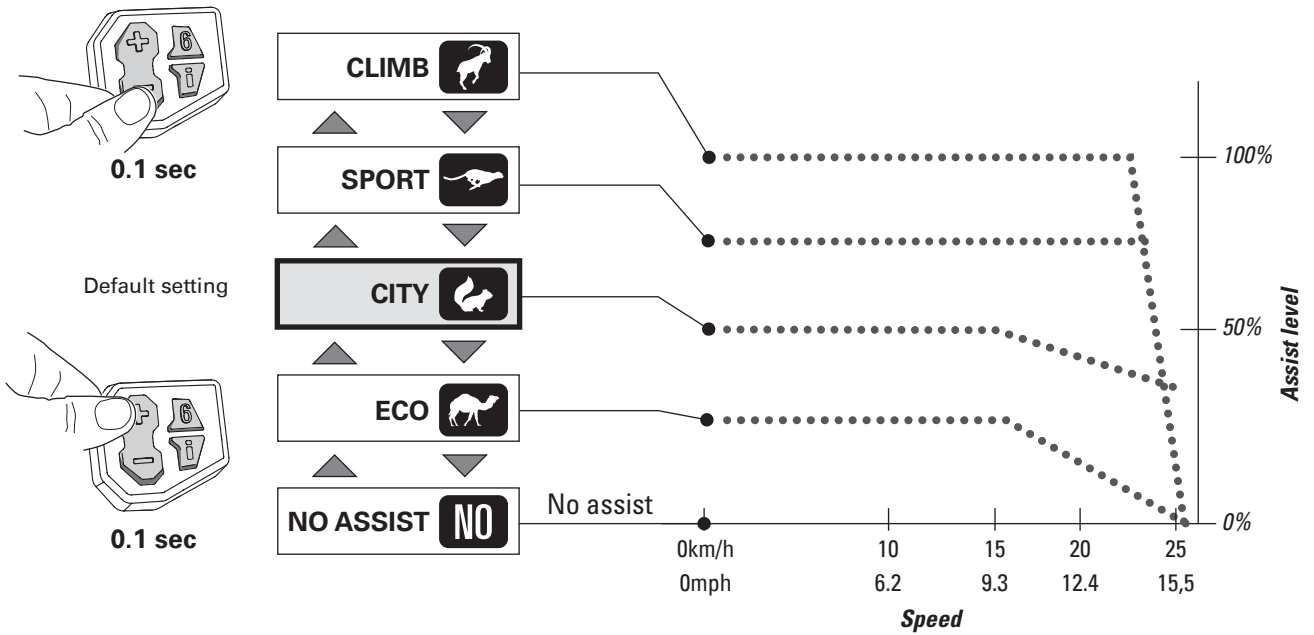

### 3. Assist level indicator

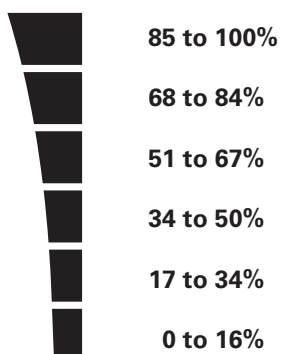



## 4. Battery State of charge (SOC)

Press the button briefly, one of the following patterns of the LEDs will be displayed.

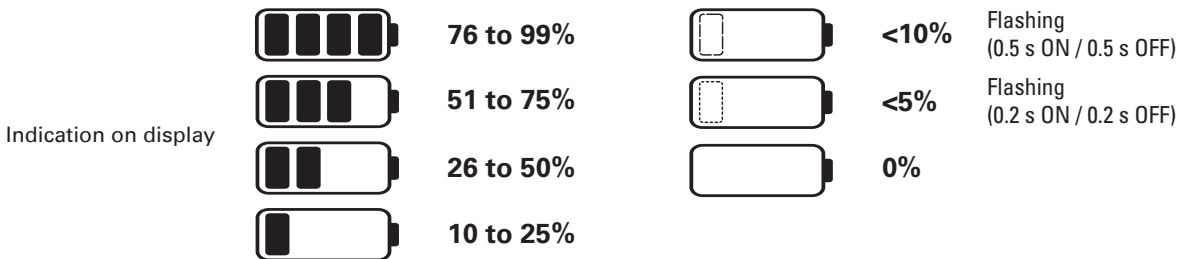
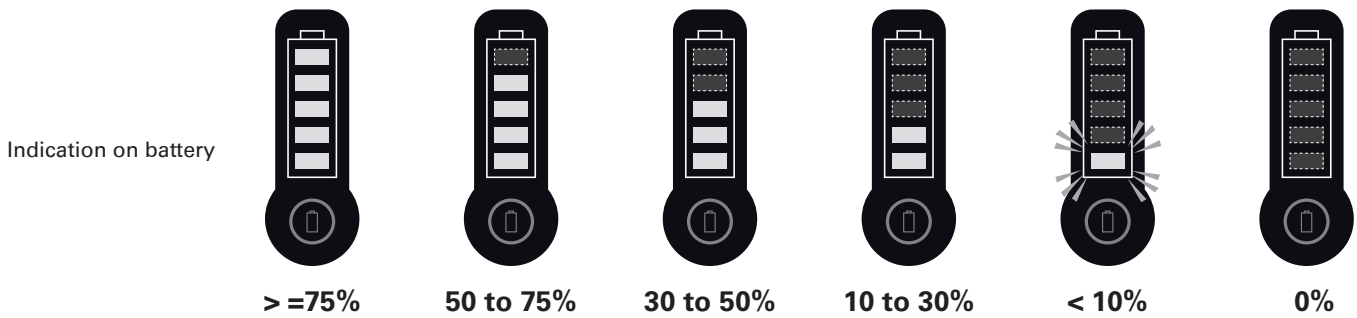

Note:  
When the battery charge level has reached less than 5%,  
the output power will be reduced.

## 5. Range

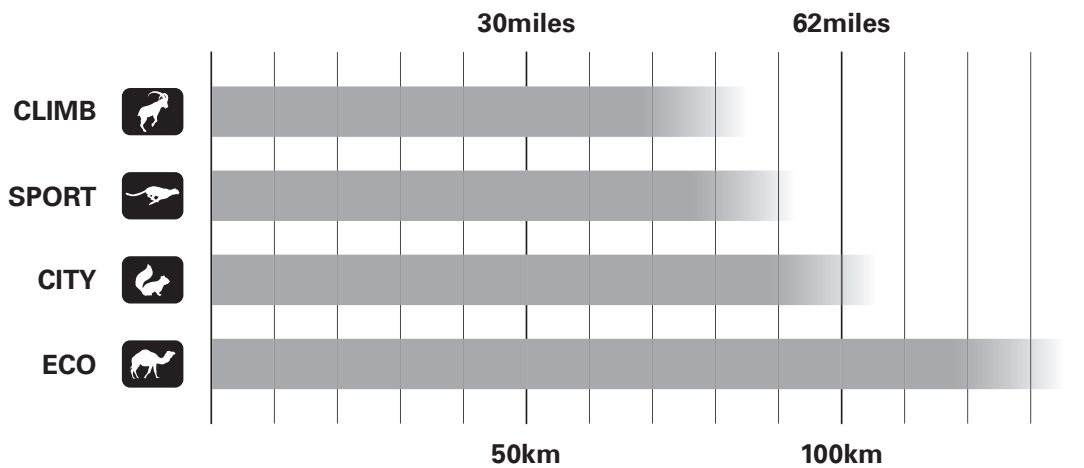

### Factors which affect the range

The above figures are based on a speed of 20 km/h on a level road at 15°C–20°C.  
The range is influenced by many factors:

- ▶ Weight of the rider
- ▶ Weight of the luggage
- ▶ Selection of path
- ▶ Experience and concentration of the rider
- ▶ State of maintenance of the E-Bike
- ▶ Type, condition and air pressure in the tires
- ▶ Nature of the route
- ▶ Speed, average speed and changes in speed
- ▶ Traffic flow, for example, stop and go
- ▶ Wind direction and wind speed

For information on using the battery, see pages 3, 4 and 8. You'll also find information on how to maintain capacity and extend duration.

**6. Changing trip information**

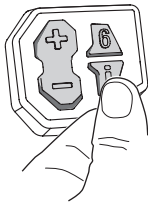

**0.5 sec**

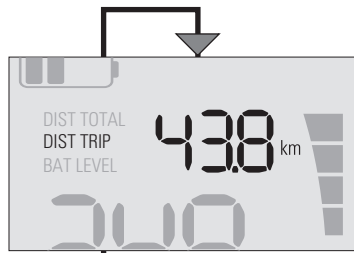

**DIST TRIP:**

Distance travelled  
Unit: 0.1 km  
Measurement range: 0.0 to 999.9 km  
(default setting)

RESETTING  
TRIP DISTANCE

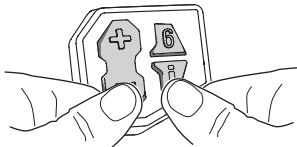

**0.5 sec**

(- & i) key



**BAT LEVEL:**

Battery charge level  
Unit: %  
Measurement range: 0% to 99%

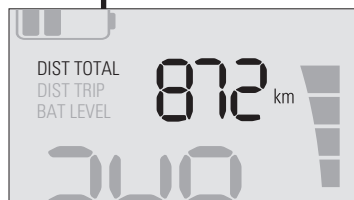

**DIST TOTAL:**

Cumulative distance  
Unit: km  
Measurement range: 0 to 9999 km

**7. Changing background lighting**

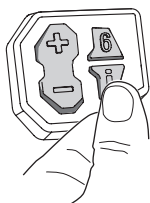

**2 sec**

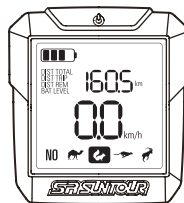

**Daytime** (default)  
100% illumination

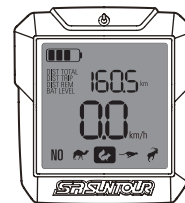

**Nighttime**  
50% illumination

**Note:**

The on and off at nighttime automatically switches the headlights on and off (if any).

## Headlight and taillight (if applicable)

**Power on/off**

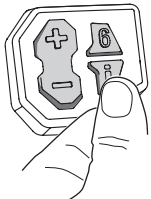

**2 sec**

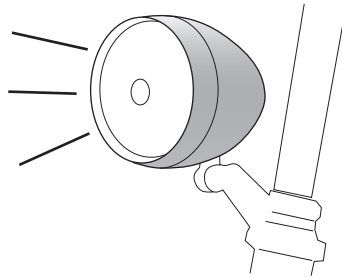

**Technical data**

Nominal voltage 6V

Output power: 3.0 W

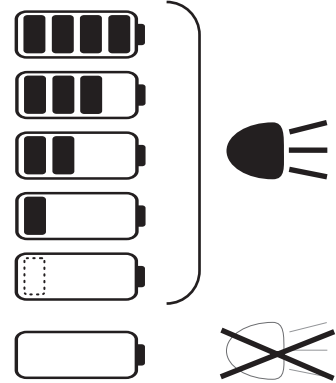

## Charging support function

Power supply for external devices via USB connector. The USB connector allows you to charge most devices with a USB connector.

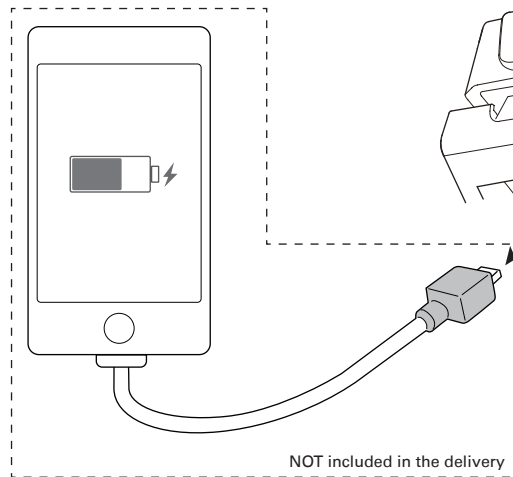

**USB connector**  
Output: 5VDC 0.5A

**! WARNING**

Cap when not in use. Always close to prevent the possible ingress of water.

## Overheating warning

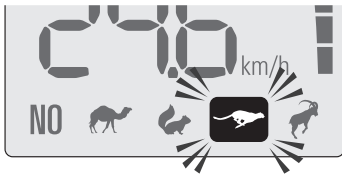

Long and sharp gradients may cause heating of the motor. Flashing of the "SPORT" mode indicates this.

If the engine really overheats, the system will switch itself off in advance to protect the components.

## Error codes

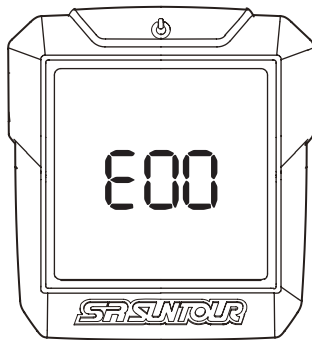

In the rare event of a system malfunction, an error message will appear on the display. If an error message appears, turn the system completely OFF and then ON. If the error message still appears, contact your local dealer for assistance.



Error codes	Error description	Troubleshooting	Solution
Error 00	Control unit communication error	Remove the battery for five minutes. Power on the system.	Replace control unit.
		Check the display contacts and the display holder.	The display or the display holder need to be replaced.
		Check the display cable between the control unit and the display.	Display holder needs to be replaced.
Error 01	Control unit overheating.	Let control unit cool.	Replace control unit.
Error 04	Bike lighting problem.	Check the lighting system of the bike.	
Error 05	Control unit data error.	Remove the battery for five minutes. Power on the system.	Replace control unit.
Error 11	Display communication error.	Check display holder contacts and cables.	Replace display or display cable.
Error 21	Torque sensor electrical problem	Check the sensor contacts.	Replace sensor unit on crank.
			Replace crank.
Error 22	Torque sensor mechanical problem	Check the sensor contacts.	Replace crank.
Error 32	Overcurrent fault	Check the battery contacts, also in the control unit.	Replace control unit.
Error 34	Overvoltage fault	Check the battery contacts, also in the control unit.	Replace control unit.
Error 41	Motor overheating fault	Let motor cool.	Motor or motor cable needs to be replaced.
Error 42	Motor sensor fault	Motor or motor cable fault	Motor or motor cable needs to be replaced.

## Installation instructions for the ATS crank unit

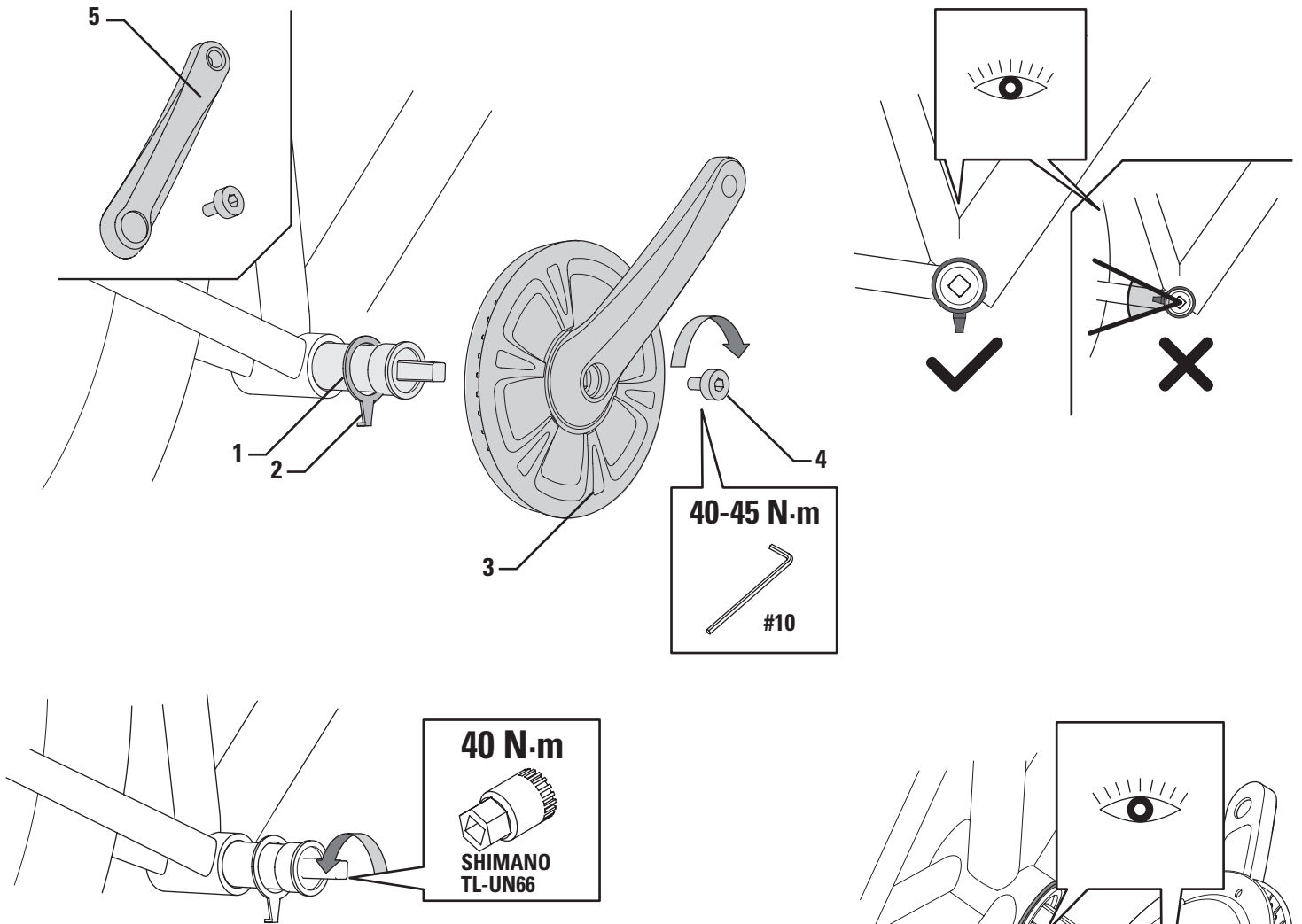

### Cleaning the crank sensor

If the bike has been used a lot, in dry dusty conditions, a build-up of dust can stop the chain wheel infra-red optical sensor from working. This would result in no assistance, even though the handlebar display would be operating normally.

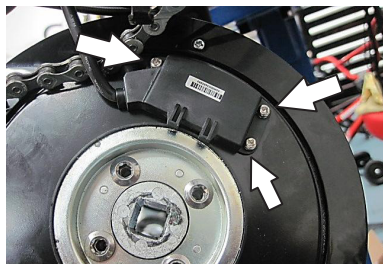

1. Remove the chain wheel.
2. Undo the three small cross head screws, to remove the sensor from the rear of the chain set (use a very small tipped No.0.5 cross head screwdriver).
3. Blow out any dust which could be obstructing the optical path (the two slots) of the two pairs of transmitters & receivers.

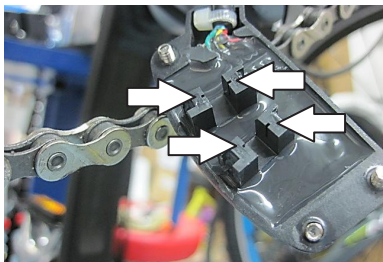

4. Reverse the above process to reassemble the sensor & chain wheel motor to the hub. Tighten the crank securing bolt to 40 to 45 Nm.

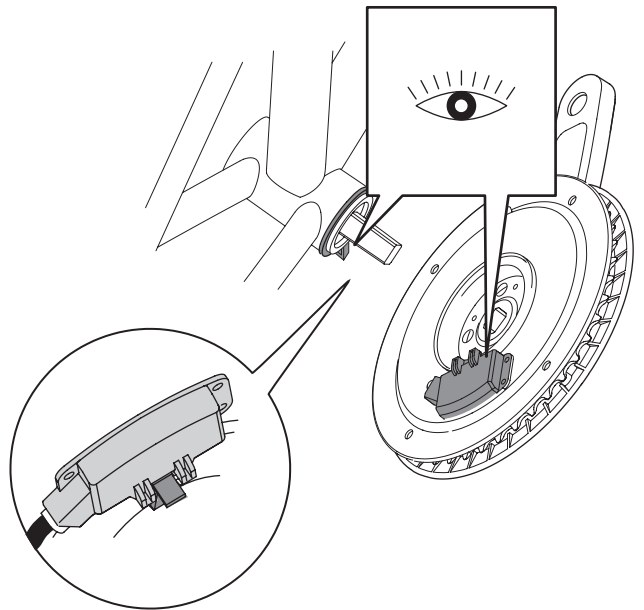

### Parts list

Part	Name	Number
1	Bottom bracket	1
2	Sensor stopper	1
3	Chain wheel with sensor	1
4	Allen screw	2
5	Crank	1

## Installation instructions for rear wheel motor

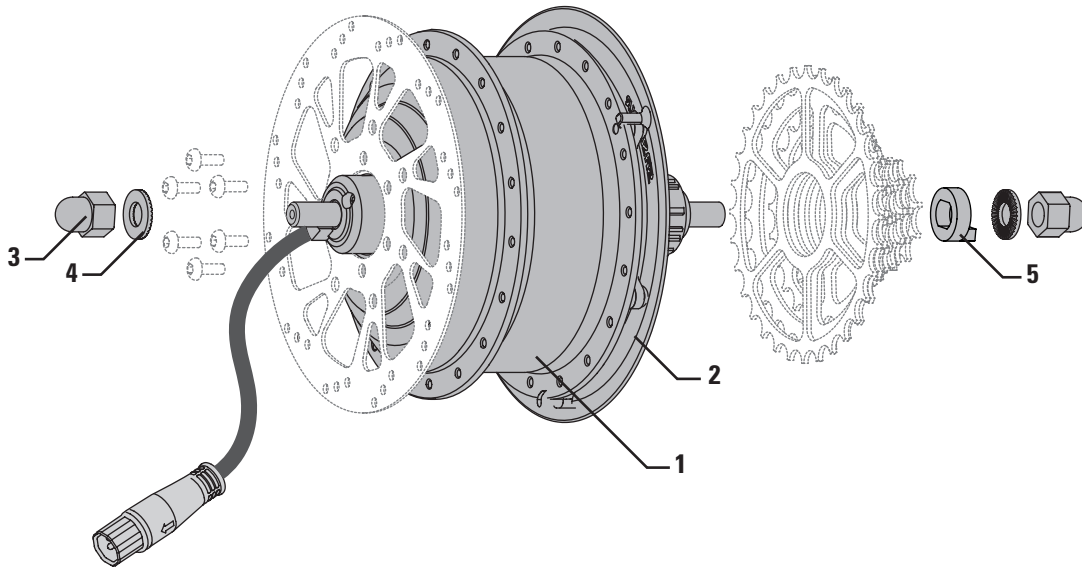

**!**  
Remove the cassette, using a Shimano cassette tool or SR SUNTOUR special cassette tool (EHX001).

**!**  
To mount the disc correctly, please follow the instructions of the manufacturer. Use M5 (0.8 mm) x 10 mm screws

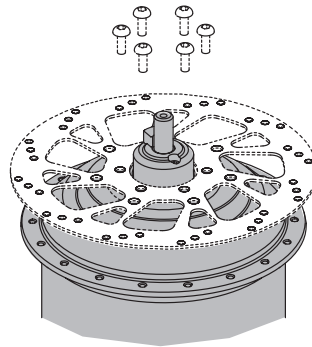

**!**  
Make sure the bolt thread screws not deeper than 10mm into the hub body. Otherwise the screw can destroy internals of the motor.

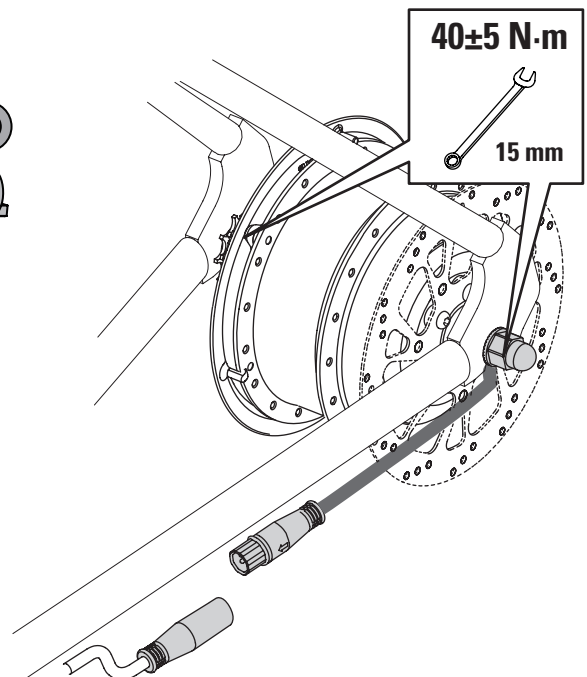
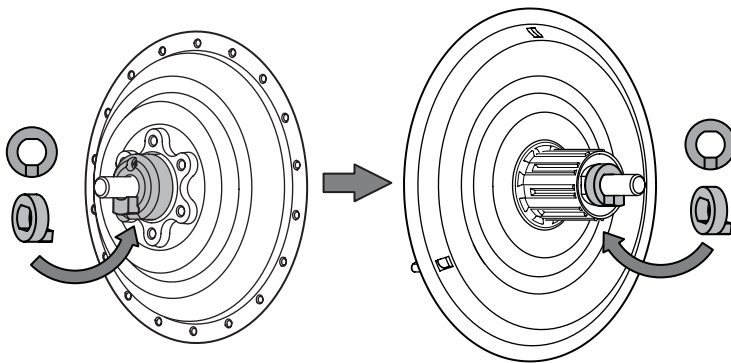

### Parts list

Part	Name	Number
1	Motor	1
2	Spoke guard ring	1
3	Cap nut	2
4	Washer	2
5	Stopper	1

**Checking connections**

There are only two 'exposed' connectors;  
 One under the non drive chainstay, for the motor cable.  
 The other in front of the handlebar, to connect the display & remote switch.

1. Separate the connectors to check that the interior & pins are clean, dry & are not corroded. Clean up as required.



2. To close the connectors push the two sides together, this will require some 'wiggling' of the connector to overcome the resistance of the sealing.



**Removing the rear wheel (to fix a puncture or replace the wheel or the motor)**



1. Cut the four cable ties to access the waterproof connector.
2. Separate the two halves of the connector, this requires some 'wiggling' of the connector to overcome the sealing.
3. Loosen the wheel nuts & remove the wheel.
4. Refit using this process in reverse.

## Removing the motor from the hub

1. Remove the drive side wheel nut, knurled washer & the 'toothed' orientation locking washer.
2. Unclip the three legs of the spoke protector & remove it.

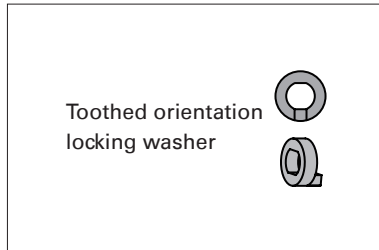

3. Remove the cassette using a standard Shimano cassette tool.



4. Loosen & remove the 6 motor fixing bolts using a T25 key. Tighten to 5 Nm on reassembly.

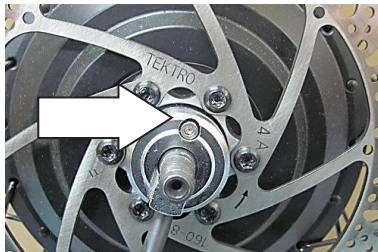

5. On the non-drive side of the wheel, remove the wheel nut & knurled washer.

6. Remove the 'toothed' orientation locking washer & cable guide, after loosening & removing the small bolt (arrow) using a 2.5 mm Allen key. Tighten to 2 Nm on reassembly.

7. Lightly tap the end of the axle on the non-drive side using a soft faced mallet.

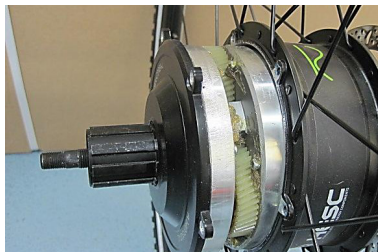

8. The motor unit will then slide out on the drive side of the hub.

9. Feed the motor cable connector through the hole at the centre of the non-drive side of the hub.



Reverse the above process to reassemble the motor to the hub.



## Glueing together of motor and hub

1. Remove the O-Ring by gently squeezing it with thumb and index fingers and lift it up by using a small allen key.

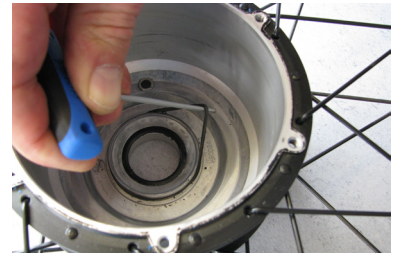

2. Clean the inner part of the hub and then carefully degrease it, especially the bearing seat.



3. Clean the inner race of the bearing and degrease it afterwards.



4. Apply Three Bond TB1521 glue on the bearing seat. Note: Never apply the glue on top, only on the seat itself so that excessive glue can release itself into the O-ring Groove

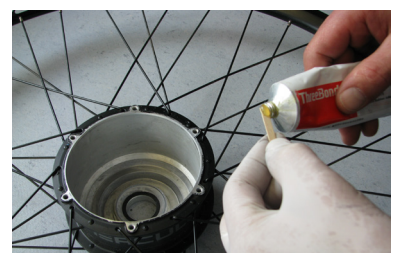
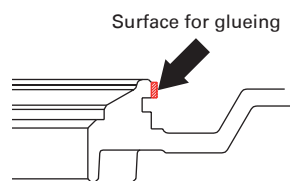

5. Press the Motor immediately into the Hub and fasten the 6 Bolt



6. Store the the motor immediately levelled with disc side up for 45min to ensure the glue being cured correctly





**Installation instructions for the rear motor display**

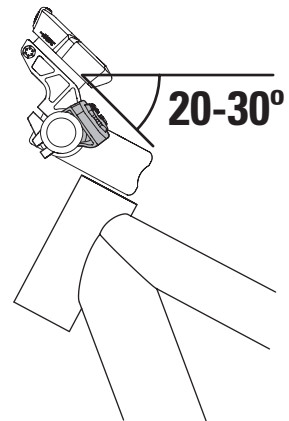
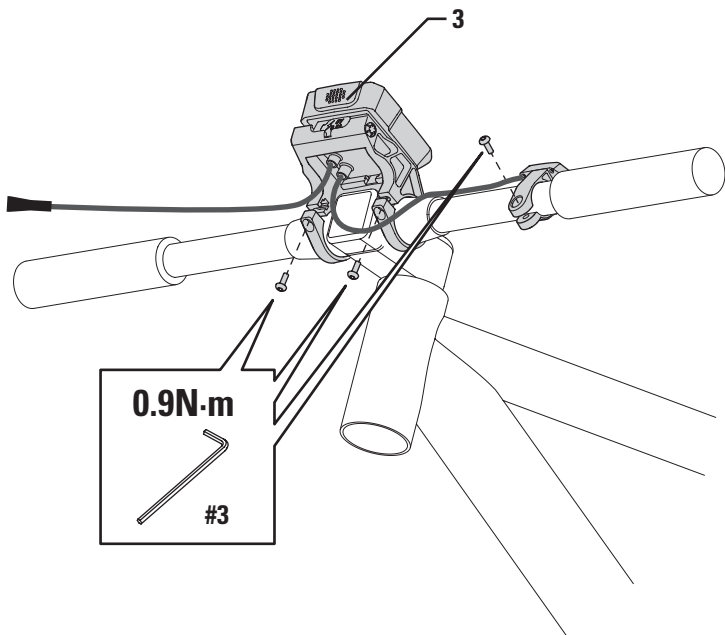
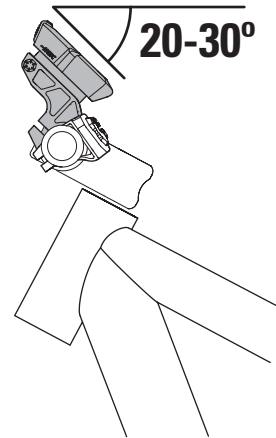
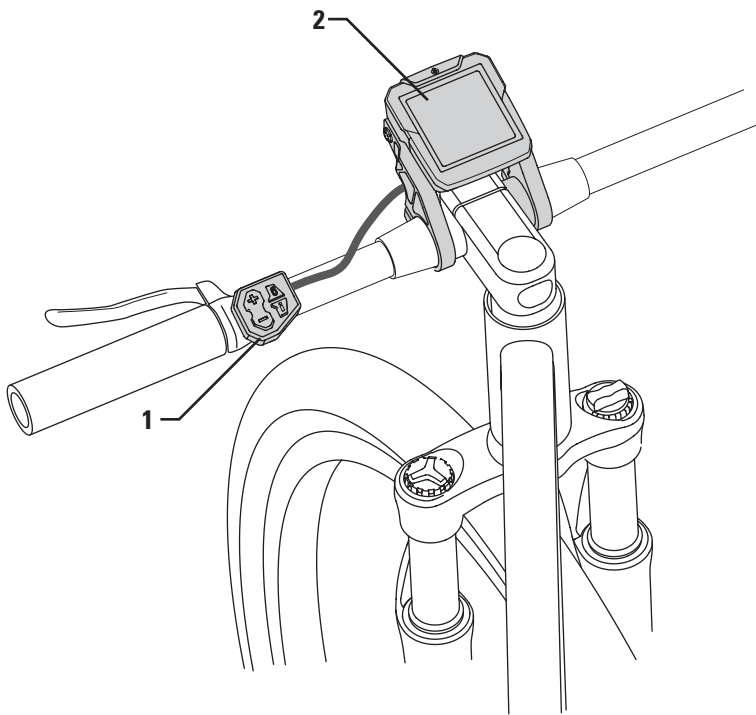

**Parts list**

Part	Name	Number
1	Holder with switch	1
2	Display	1
3	Allen screw	3

## Installation instructions for the controller

### Accessing the motor controller connectors / replacing the motor control unit

The motor control unit is housed inside the lower end of the battery carrier, mounted on the down tube.

You have to take the battery carrier off the frame to get access to remove the cover from the end of the carrier.

1. Remove the battery.
2. Undo and remove the three bolts holding the carrier to the frame (using a 3mm Allen key). Tighten to 2 Nm on reassembly.
3. Rotate the battery carrier, to gain access to the four cross head screws that hold on the cover (use a small tipped No.1 cross head screwdriver).

When the cover is removed the motor control unit is exposed

The motor cable is 'hard wired' to the motor control unit, but there are two plug in connectors which are tucked down the side of the control unit.

The four pin connector is used to connect to the crank torque sensor. You would make the connection here if you were replacing the torque sensor.

The three pin connector is used to connect to a cable that runs along the down tube for the handlebar display. You should only need to use this connector if replacing the control unit, as there is the external handlebar display connector provided just in front of the handlebar.

If replacing the motor control unit & motor cable, it can be removed from its mounting on the battery carrier by undoing the three cross head screws.

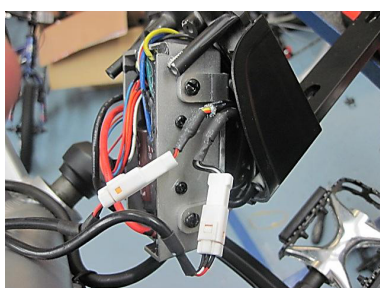
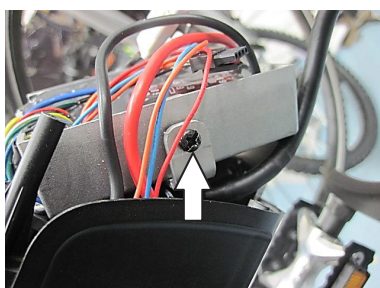
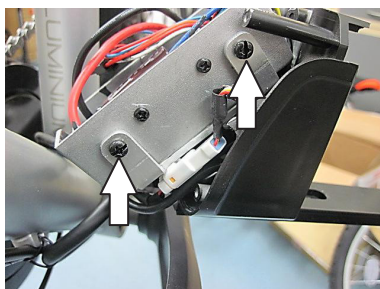

### Reassembly

Having ensured that all of connectors are securely closed, tuck the connector wires down the side of the control unit. Refit the battery carrier end cover (this is easier with the cover securing screws removed), ensuring that the cables emerge through the slots in the base of the cover. Refit the battery carrier to the down tube & replace any cable ties that had been removed.

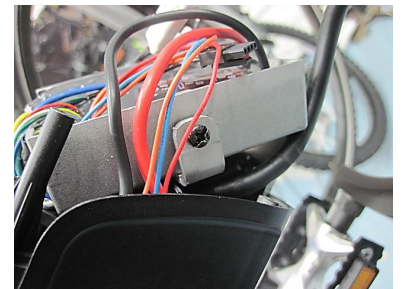
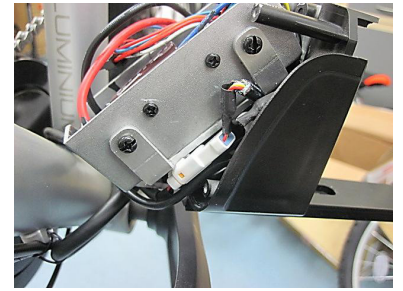



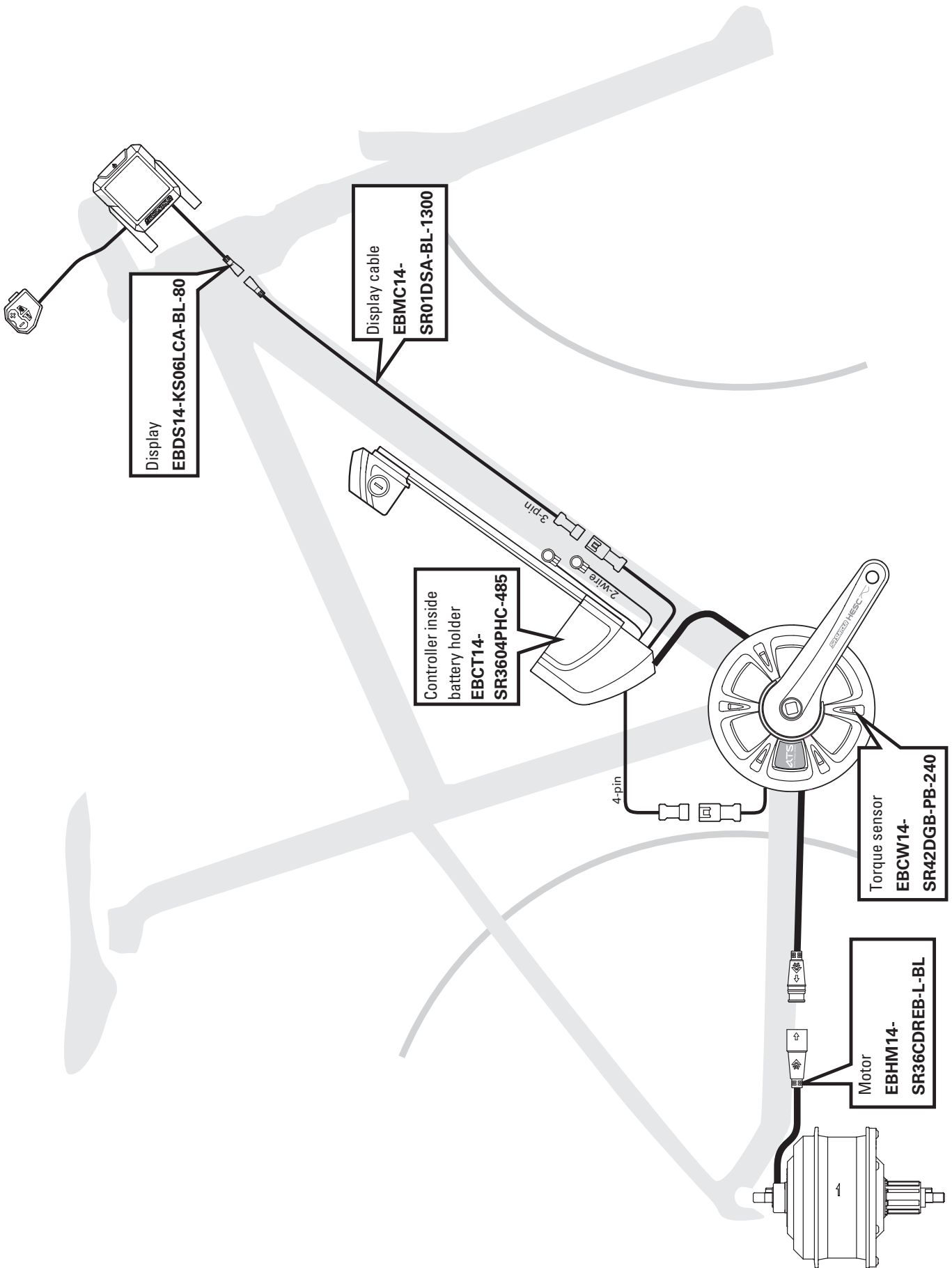



**Cable harness for the rear wheel motor**

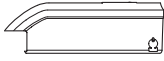

## Spare parts list for rear wheel motor

Modell	Image	Accessories			Spec.	Finish	Part number
Display		 #3 L:14mm	---	---	250mmB	lack	<b>EBDS14-KS06LCA-BL-80</b> Halfords item No. 169114
Display cable		---	---	---	1300mm	Black	<b>EBMC14-SR01DSA-BL-1300</b> Halfords item No. 169122
Torque sensor/ Crank			---	---	42T Crank l: 170mm cable l: 240mm	Black	<b>EBCW14-SR42DGB-PB-240</b> Halfords item No. 169205
Sensor stopper		---	---	---	For 73mm BB	Black	<b>EBSS14-SR42BBB</b>
Bottom Bracket		 #10	---	---	73mm width 136mm axle length	Black	<b>BB15-ATS-SQS136-CBT-73mm</b> Halfords item No. 169213
BB Spacer		---	---	---			<b>EBC040 BB LEFT CAP</b>
Motor Cassette type		 Domed cap nut 15mm	 Washer	 Dust cover	Cassette type 250W	Matt black	<b>EBHM14-SR36CDREB-L-BL</b>
		 Chain guard	 #3 L:10mm	 Locking washer			

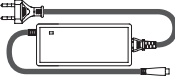
Modell	mage	Accessories			Spec.	Finish	Part number
Battery		---	---	---	116Ah 8.6Ah	Gray	<b>EBBA16-PH3612DTA-GY</b> Halfords item No. 169197
Controller/ Battery holder			 +,8mm	 +,14mm	Downtube mount	Gray	<b>Battery holder (w/o controller box, with 4pcs of keys) EBBH14-PH36WCA-GY</b> Halfords item No. 169130
		4x 	---	---			<b>Controller box EBCT16-SR3604APD-485 (CAB*3 280)</b> Halfords item No. 169163
Battery charger		---	---	---	Plug: type CB	lack	<b>EBBC16-PH3602B</b> Halfords item No. 169189

## BATTERY CHARGER INSTRUCTION MANUAL

2015-05-05

Battery Charger ; EBBC14-PH3602A

### MANUAL BRIEF

This Manual is an additional exposition for correct use of the charger and attentions. All safety and operating instructions should be read before the equipment is installed or operated. If nothing from the following mentioned instructions would help with your problem, please contact the distributor or SR SUNTOUR. Please keep this manual for future reference. Please hand over this manual which the ownership is transferred.



### WARNING

1. This charger is designed as a Lithium-ion Battery Charger especially for SR SUNTOUR. Do NOT apply this charger for any other electrical systems.
2. The charger can be used with the input voltage range between 100-240 VAC.
3. Please use the power form domestic AC outlet.
4. Always disconnect unit from the AC power outlet when the charger is not in use.
5. Keep away this charger from infants, children or pets.
6. Keep your hands dry when operating the plug and socket.
7. Do not operate this product outdoor, near water or in areas with wet floors, in high humidity atmosphere where condensation forms on the equipment.
8. Do not dash this product with hard force or let it fall.
9. Do not try to disassemble or modify this product.

### INSTRUCTIONS

1. Regarding the charging, please also refer to the Lithium-ion battery operation instructions from SR SUNTOUR.
2. Please connect the charger's DC connector to the battery socket.
3. Please plug the AC power cord to the AC wall socket.
4. The LED lights indicate the following status:
  - Red light: Charging
  - Green light: Charging complete or battery and battery charger are not connected
5. When charging procession is completed, please un—plug the AC power cord from the AC wall socket.
6. Please un-plug the charger's DC connector from the battery socket
7. Please only charge between temperature 5°C~35°C.
8. When the LED light shows abnormal signals or cannot charge properly, please check the followings.
  - ▶ Red light or green light does not show: Make sure the AC power cord is connected to both the AC house wall socket and the charger properly.
  - ▶ Green light shows: Make sure the charger connector is properly connected to the battery.
  - ▶ Red light flashing: Please un-plug the AC power cord from the AC house wall socket, and then plug the AC cord back in the AC house wall socket.

If problem is not solved, please contact the stores or company. Do not disassemble or reconstruct the charger.

SR SUNTOUR EUROPE GMBH

Riedstrasse 31  
83627 Warrngau  
Germany  
Phone: + 49 (0)8021 50 793-30  
E mail: service@srsuntour-cycling.com

## Frequently asked questions

Fault	Possible cause	Cause	Solution	
Drive cannot be switched on with the on/off switch on the display.	Battery has no capacity.	The battery is not charged.	Check the indicator light directly on the battery. Charge the battery if the battery indicator flashes.	
	The E-Bike was not used for 48 hours or longer.	If the battery is not used for 48 hours or longer, it will automatically go into sleep mode.	Press the power button on the battery for three seconds.	
	Charging cable	The connector consists of magnetic parts that attract iron particles.	Clean the connectors of the charging cable on the bike frame and the battery.	
	Remove the battery from the holder and check the indicator lights again.	Then you can check if the battery is charged or if the problem is to be found between the battery and the control unit.	Check the battery, the connection cable to the control unit and the control unit. Replace defective parts.	
No assist for speeds between 0 and 25 km/h.	No signal between the control unit and the display	Connection problem between the control unit and the display.	Check the connections on the control unit, display bracket and display plugs.	
	Motor assistance only turns on when pressure is applied to the pedals and they are stepped.	The system has a rotation and torque sensor.	Depress the pedals with sufficient pressure.	
	The display is on, but there is no assist.	Assist mode "NO" is selected.	There is no assist.	Set a different mode.
		Note: If the speed is higher than 25 km/h there will be no assist.	With a Pedelec, assist stops after a speed of 25 km/h.	There is only assist at speeds between 0 and 25 km/h.
		The battery is nearly empty and the indicator light begins to flash.	Assistance is not uniform in this case, or non-existent.	Charge the battery.
		An error code appears on the display: Err " "	During the automatic verification of the E-Bike system an error was detected.	Compare the code with the error code list for further proceedings.
A reset is required.		1) Restart the E-Bike system. 2) Remove the battery for at least 60 seconds, put the battery back in and start the system again. 3) Check all cable connections.		
No signal between the control unit and the display	Problems with the motor cable or the motor cable connections.	Check the connections of the motor cable to the motor and the control unit.		
The sensor emits no signal.	Sensor defective or connection problem.	Check the connections of the sensor unit in the control unit. Replace the sensor unit.		
The push assistance does not work.	A reset is required.		Switch off the E-Bike system and then back on.	
	Check whether the assist works while riding.	This way you can check that the motor and the control unit are working.	Replace the display holder. Replace the control unit.	
	Wired handlebar remote control defective.	Wired handlebar remote control defective.	Replace the sensor unit.	
The assist is too weak.	Check battery capacity.	Checking with the switch on the battery.	Charge the battery or fully discharge and recharge the battery.	
	Error in the sensor unit.	The sensor measures the pressure with which the pedal is depressed.	Replace the sensor on the chain wheel.	
	Transmission damage or bearing defect.	The motor moves heavily.	Replace the motor.	
	The control unit does not work.	The control unit regulates assistance.	Replace the control unit.	
The motor is running roughly.	Problem with the connection of the motor cable.	Loose connection	Check and/or clean the connectors, especially the connection of the motor cable.	
	Transmission damage or bearing defect.		Replace the bearing or the engine.	
	Fault in the sensor unit.	The sensor measures the pressure with which the pedal is depressed.	Replace the sensor on the chain wheel.	
	Uneven performance of the control unit.	Faulty part in the control unit.	Replace the control unit.	

Fault	Possible cause	Cause	Solution
Sudden shutdown of the system.	Check or replace the recharging connector.	The connector consists of magnetic parts that attract iron particles.	Clean the connectors of the charging cable on the bike frame and the battery.
	Problem with the cable connection.	A poor connection interferes with signal transmission.	Check all connectors in the E-Bike system.
	Problem with the display connections.	Check the connections on the display.	Replace the display or the display holder.
	Twisted battery holder.	Twisted mechanical interface.	Adjust the battery holder.
Short range	Check battery age and recharge cycles.		Check with the switch on the battery.
	Check the battery capacity. Charge the battery if needed.	The range is reduced with poor road conditions.	Check the remaining capacity of the battery, either on the display or on the battery.
	The range depends on various factors, including: maintenance of the wheel, starting and stopping, gear selection, assist mode, tire pressure, weight of the rider, terrain, temperature and wind direction.		Check general conditions as described under "possible causes."
	Charger defective.	The charger is not charging properly.	Check the charger.
	The battery was charged at a cold temperature.	The battery should be charged at room temperature.	Charge at room temperature.
	Low temperatures.	Performance decreases below 15°C.	Lithium-ion batteries have up to 40% less capacity at temperatures below 0°C.
	Maintenance status of the E-Bike.	Irregular service on the E-Bike can reduce the range significantly.	Check all standard functions of the E-Bike, such as brakes, tires, etc.
The lighting does not work.	The 6V needed for lighting are not available.		Check whether the control unit supplies 6V. Measure the voltage on the red and black wires of the control unit. Replace the control unit if 6V are not measured.
	Lighting is activated with the "I" button on the remote control.		Press "I" for two seconds.
	The lighting system is defective.	A short circuit in the wiring can cause the problem.	Check the lighting unit and the cable.
	The E-Bike system is turned off.	The lighting only works if the E-Bike system is turned on.	Switch the system ON.
No change of riding mode is possible.	The button on the remote control does not work.		Replace the display and/or the holder.
	The control unit does not work.		Replace the control unit.
The speed display is faulty or irregular.	The signal between the speed sensor in the motor and the display is distorted.	Poor contact.	First check the connections of the motor cable. Then check the connections to the control unit. Check the cable to the display and the connections to the holder.
	The speed sensor is faulty.		Replace the "internal motor."
Distance is not being saved.	Faulty control unit.	The functions of the speedometer are stored in the control unit.	Replace the control unit.
The system will not switch off.	Power button on the display.	Press the power button for about two seconds.	Replace the display holder or control unit.



**Notes**

## Contact

SRSUNTOUR Europe GmbH (Sales and Service)  
Riedstrasse 31  
83627 Warngau  
Germany

Opening times: Monday – Friday 9 am – 5 pm

General phone: +49 8021 50793-0  
E-Bike phone: +49 8021 50793-15  
Spare parts phone: +49 8021 50793-11  
Fax: +49 8021 50793-29  
Email: [service@srsuntour-cycling.com](mailto:service@srsuntour-cycling.com)  
[hesc@srsuntour-cycling.com](mailto:hesc@srsuntour-cycling.com)

SRSUNTOUR Düsseldorf GmbH (Sales)  
Kieshecker Weg 153  
40468 Düsseldorf  
Germany  
Phone: +49 2119 84366-22  
Fax: +49 2119 84366-23